

## Transmission Assembly - Dismantle and Reassemble (Transmission Removed) (16 118 8)

(MTX 75 Transmission 4x4)

### Special Tools

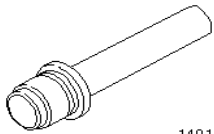

14010

14-010 Installer, bearing cups

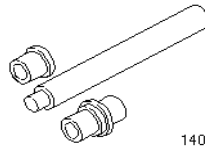

14011

14-011 Installer, selector shaft oil seal

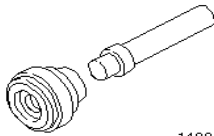

14024

14-024 Installer, bearing cups

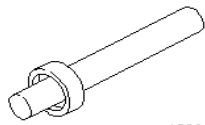

15025A

15-025 A Installer, differential bearing



15026A01

15-026A-01 Thrust pad

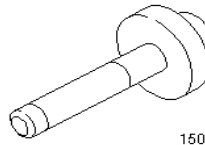

15036

15-036 Installer, differential bearing

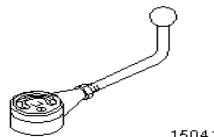

15041

15-041 Preload gauge

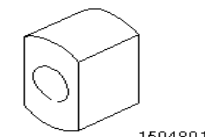

1504801

15-048-01 Adapter

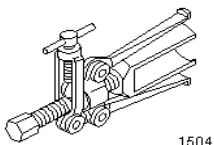

15048

15-048 Puller, bearing outer races

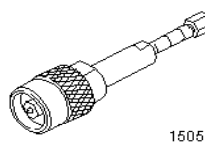

15050A

15-050 A Remover, taper roller bearing (basic tool)

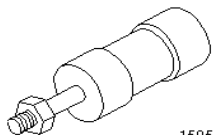

15053

15-053 Slide hammer

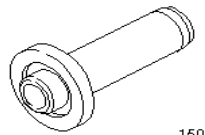

15058

15-058 Installer, differential oil seal

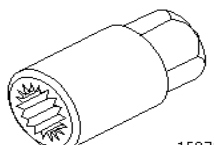

15073

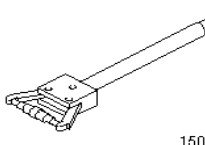

15074

15-073Socket

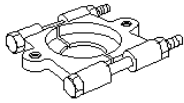

T115091

15-074Remover, bearing outer races

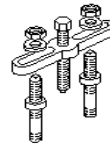

15092

15-091Separator

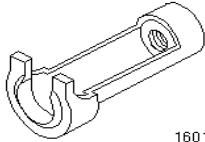

16019

15-092Bridge, separator

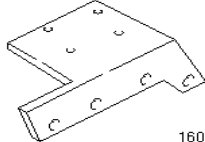

16058

16-019Remover/installer, selector shaft oil seal

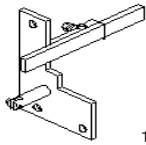

16059

16-058Mounting plate, transmission

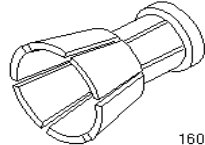

16060

16-059Measuring fixture, input shaft end float

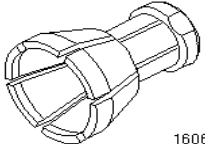

16061

16-060Collet for 15-050 A

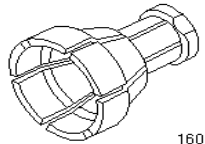

16062

16-061Collet for 15-050 A

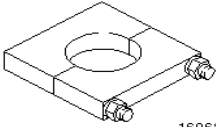

16063

16-062Collet for 15-050 A

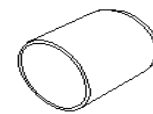

1606601

16-063Support plate, gear removal

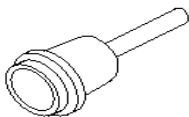

16066

16-066-01Guide sleeve, double lip oil seal

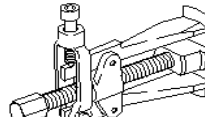

16074

16-066Installer, double lip oil seal

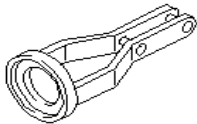

2102402

16-074Remover, Driveshaft Oil Seal

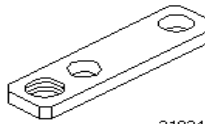

2102407

21-024-02Adapter for 21-024

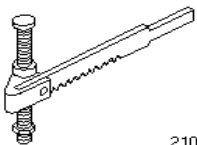

21024

21-024-07Adapter for 21-024

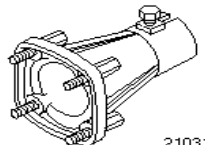

21031B

21-024Valve spring compressor

21-031 BMounting plate, transmission

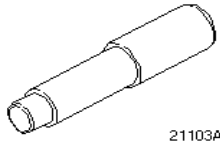

21103A

## 21-103 ARemover/installer, selector shaft ball sleeves

### Proprietary Tools

Magnetic fixture
Dial gauge
Hot air gun

### Materials

High temperature grease	ESD-M1C220-A
Transmission fluid	ESD-M2C186-A

### Workshop Equipment

Press	
-------	--

### Measurement shims

	Input shaft	Output shaft	Differential
Measuring shim: mm	1,00	1,00	1,10

## Dismantle

1. General note.

### Note:

For transmission repairs, always consult TSB No. 192/1996. If the concern is not described in the TSB, it is not necessary to renew the listed parts.



### CAUTION:

Parts from the TSB are not identical.

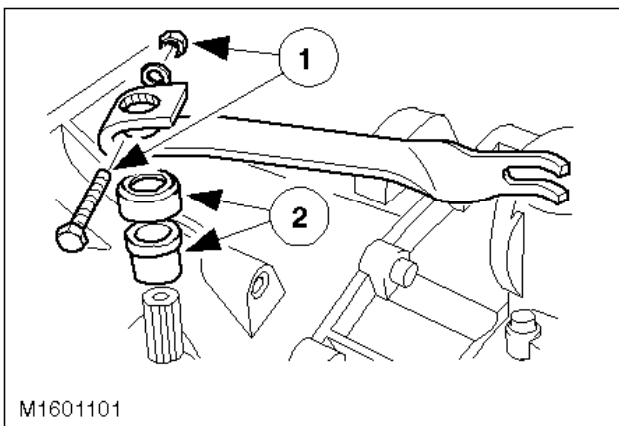

M1601101

- ☛ 2. Detach the clutch release lever.
- 1 Remove the bolt, disconnect the clutch release lever.
  - 2 Withdraw the gaiter and the bearing bush from above.

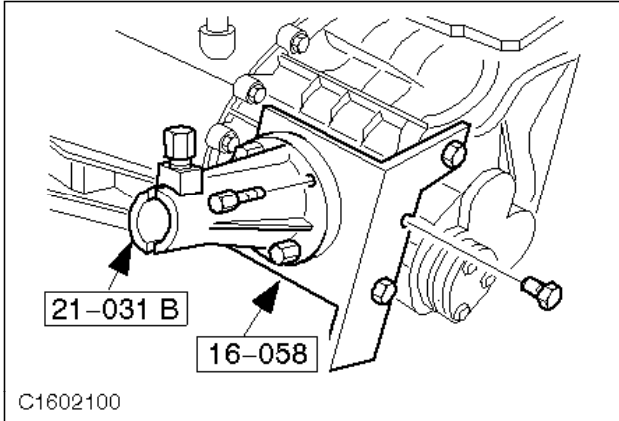

- ☛ 3. Attach the special tools.

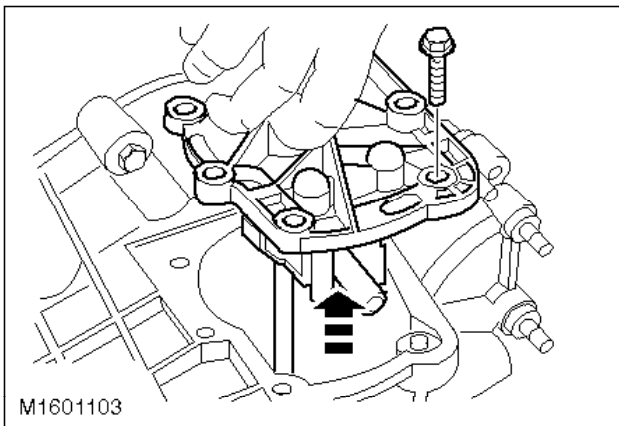

- ☛ 4. Remove the gearshift mechanism.
- Put the transmission in neutral.
  - Unscrew the bolts (6 x).
  - Pull out the gearshift mechanism assembly from above.

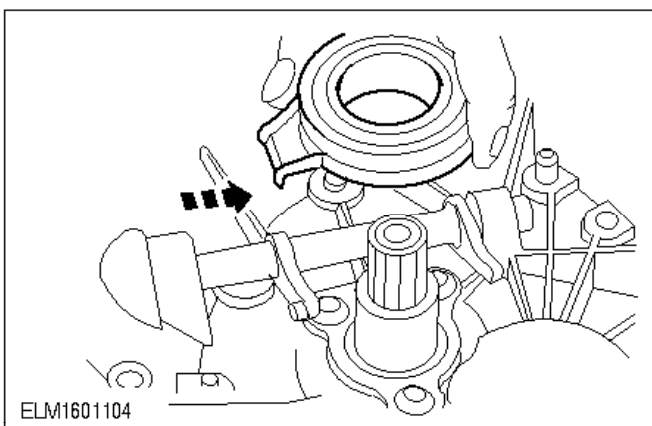

- ☛ 5. Remove the thrust bearing and the release shaft.

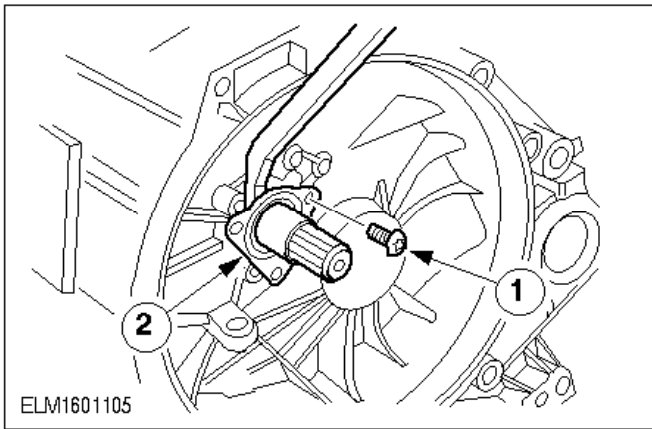

6. Remove the guide sleeve.
- 1 Undo the three retaining bolts.
  - 2 Twist the guide sleeve and prise it off.

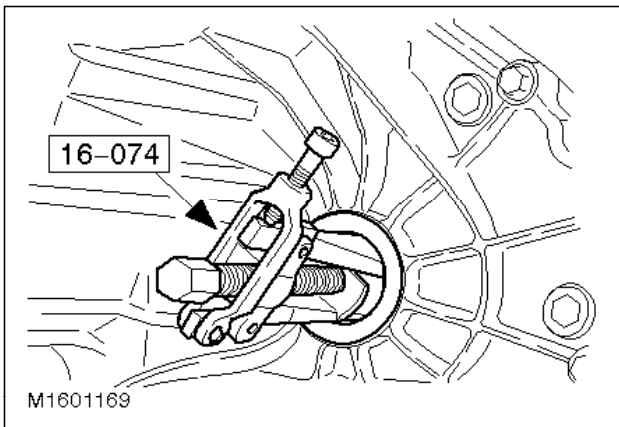

### Remove the driveshaft oil seals

7. Pull out the front driveshaft oil seals with the special tool.

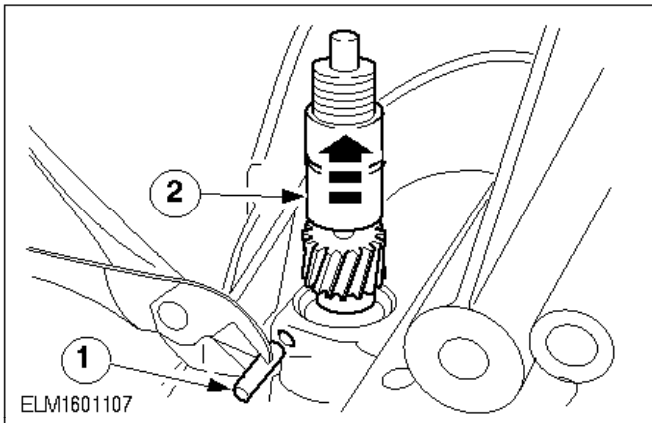

8. Remove the speedometer drive gear.
- 1 Withdraw the roll pin.
  - 2 Remove the worm gear.

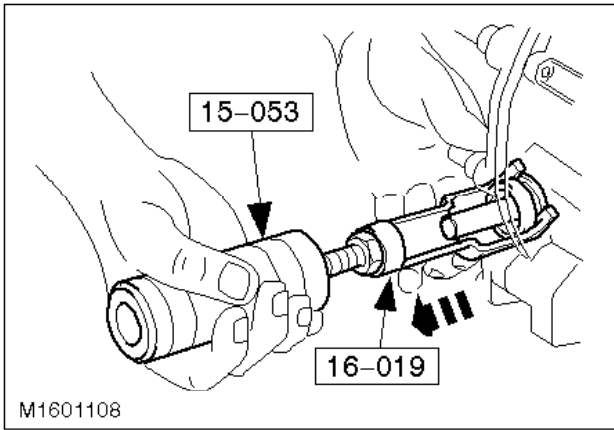

**Detach the selector shaft oil seal.**

- 9. Pull off the oil seal using the special tool.

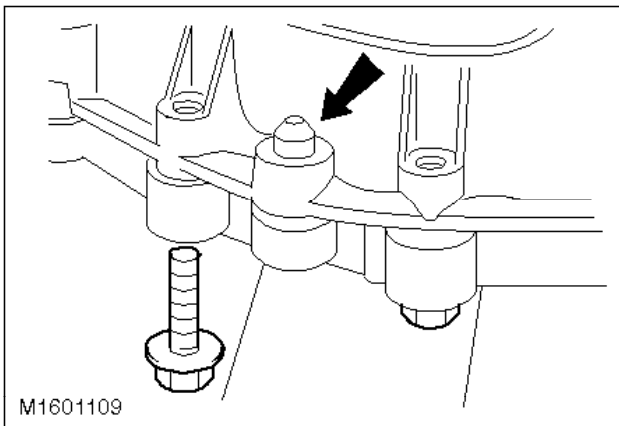

Note:  
Do not drive out the dowel pins.

- 10. Unscrew the transmission housing connecting bolts.

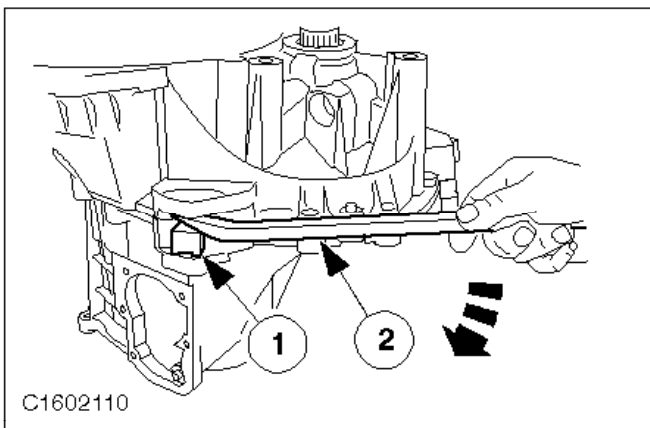

- 11. Separate the transmission housing sections.

**⚠ CAUTION:**  
Do not damage the transmission housing.

- 1 Use a support.
- 2 Separate the housing sections using two levers positioned opposite each other.

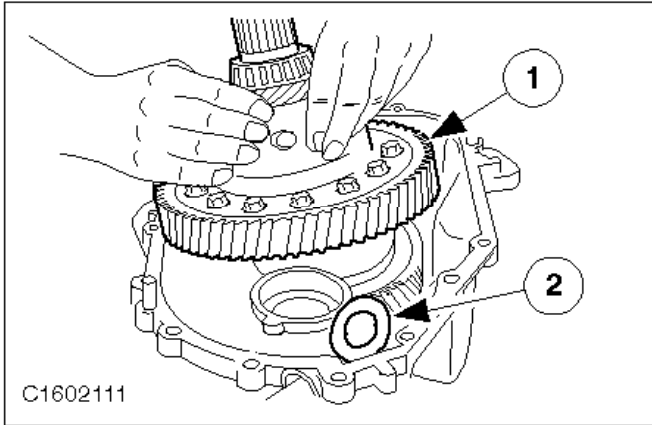

12. Remove the differential.

- 1 Lift out the differential assembly.
- 2 Take out the magnetic disc.

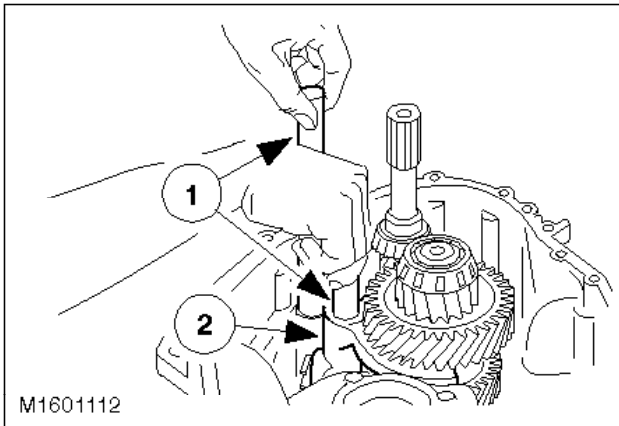

13. Remove the selector rods and selector fork.

- 1 Remove the selector rods.
- 2 Take out the selector fork for 1st/2nd gear.

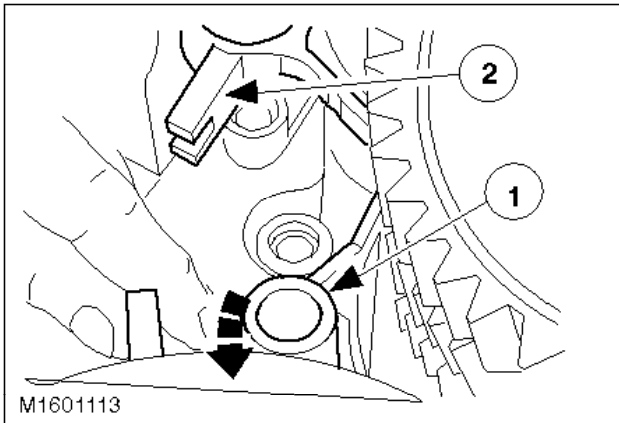

14. Remove the selector forks.

- 1 Selector fork for 5th/reverse gear. Swivel the gear wheel to one side.

- 2 Turn the selector fork for 3rd/4th gear and remove it.  
Selector fork for 5th/reverse gear. Remove the gear wheel.

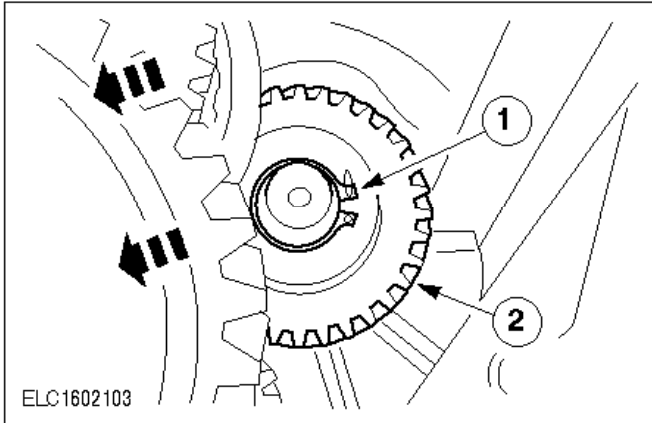

15. Remove the reverse idler gear.

- 1 Remove the snap ring.  
Swivel the input and output shafts to one side.
- 2 Take off the reverse idler gear from above (see following step for removal sequence).

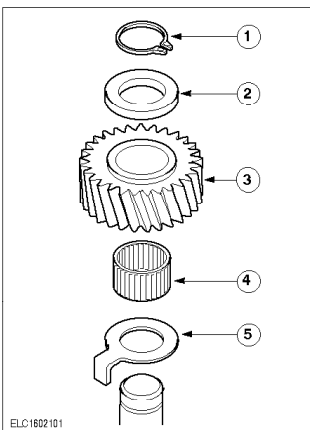

16. Removal sequence for reverse idler gear.

- 1 Circlip
- 2 Upper thrust washer
- 3 Reverse idler gear
- 4 Needle roller bearing
- 5 Lower thrust washer



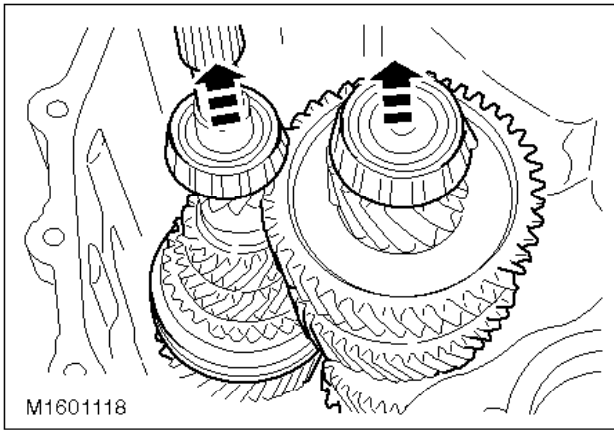

17. Remove the input and output shafts.

- Lift the input and output shafts together out of the transmission housing.
- Take out the pedestal and reverse gear idler with the needle roller bearing and thrust washers.

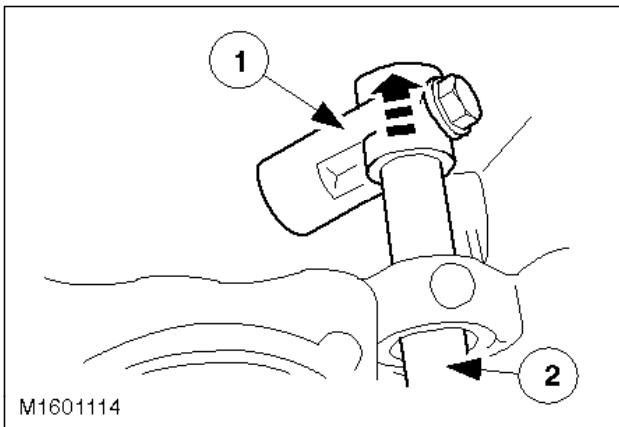

18. Remove the selector shaft.

- 1 Unscrew the ball socket and pull it off the selector shaft.
- 2 Pull off the selector shaft.

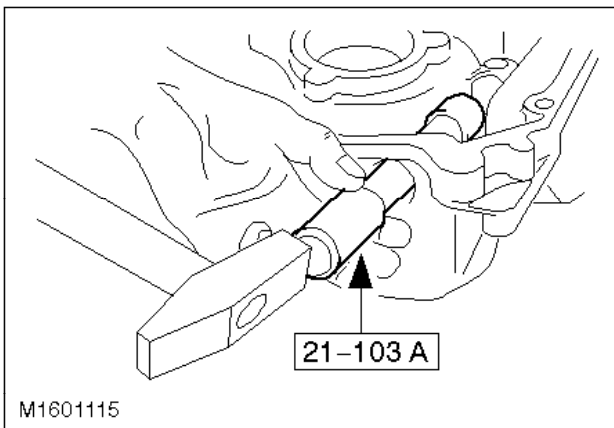

19. Remove the selector shaft ball sleeves.

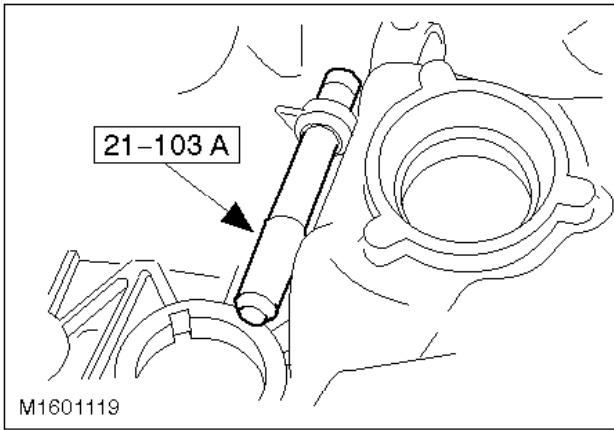

- 20. Remove the inner selector shaft bearing bush.

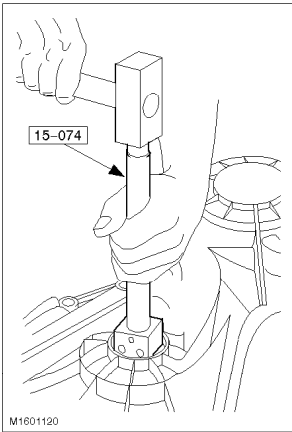

### Remove the bearing rings

Note:  
Locate the Special Tool in the transmission recesses.

- 21. Remove the differential bearing rings.

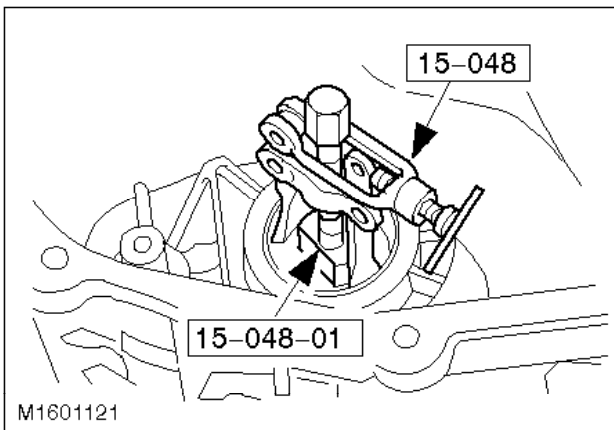

Note:  
Locate the Special Tool in the transmission recesses.

- 22. Remove the bearing rings from the input and output shafts.

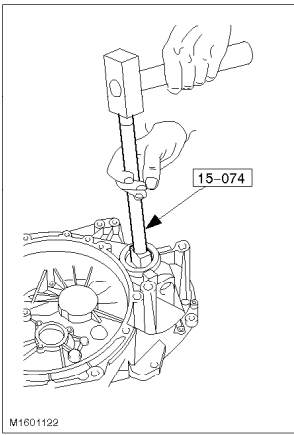

Note:

Locate the Special Tool in the transmission recesses.

23. Remove the bearing rings and the shim.

- From the input shaft.
- From the differential.

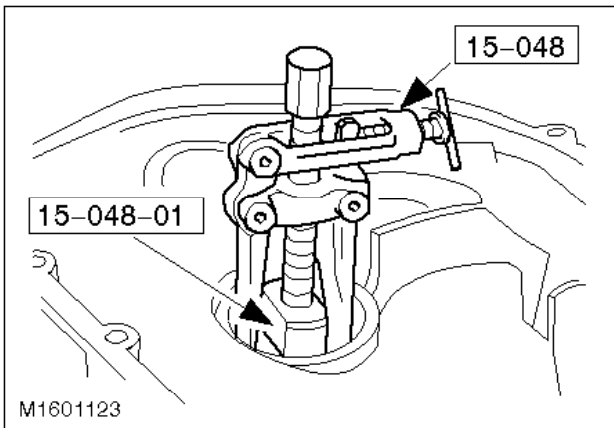

Note:

Locate the Special Tool in the transmission recesses.

24. Remove the output shaft bearing ring and the shim.

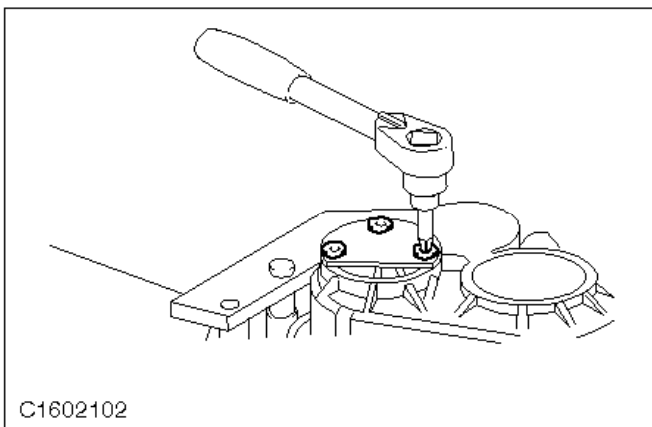

Note:

Carry out only in the event of damage or leakage.

- 25. Remove the reverse gear idler shaft.

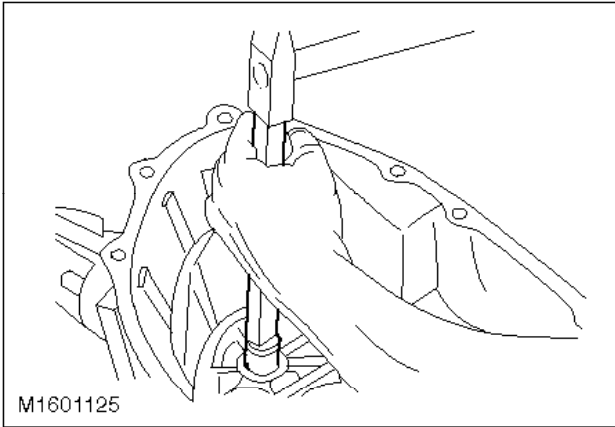

Note:

See previous step.

- 26. Drive out the reverse gear idler shaft using a piece of hardwood.

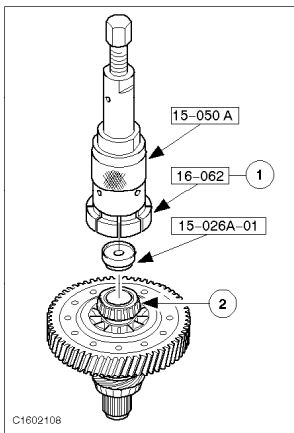

### Dismantle the differential

- 27. Pull the taper roller bearing off the differential.

- 1 Insert the thrust element.
- 2 Pull off the taper roller bearing.  
Remove the speedometer worm gear.

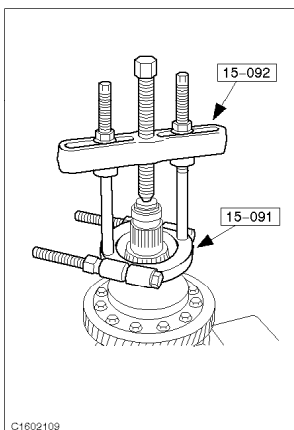

- 28. Pull the taper roller bearing off the differential.
  - Chisel open the speedometer worm gear.
  - Pull the taper roller bearing off using the separator.

Note:

Do not dismantle the differential any further.

- 29. General note.

Note:

From model year '95 a double synchroniser is installed for 1st, 2nd and 3rd gears. The layout and assembly of the single synchroniser for 3rd gear is identical to that for 4th gear. The steps described below refer to the double synchroniser. Refer to the Technical Data table for details of replacement synchroniser parts.



**CAUTION:**

**The inner synchroniser ring and the synchroniser cone must be handled with great care.**

The layout and assembly of the single synchroniser for 3rd gear is identical to that for 4th gear. The steps described below refer to the double synchroniser. Refer to the Technical Data table for details of replacement synchroniser parts.

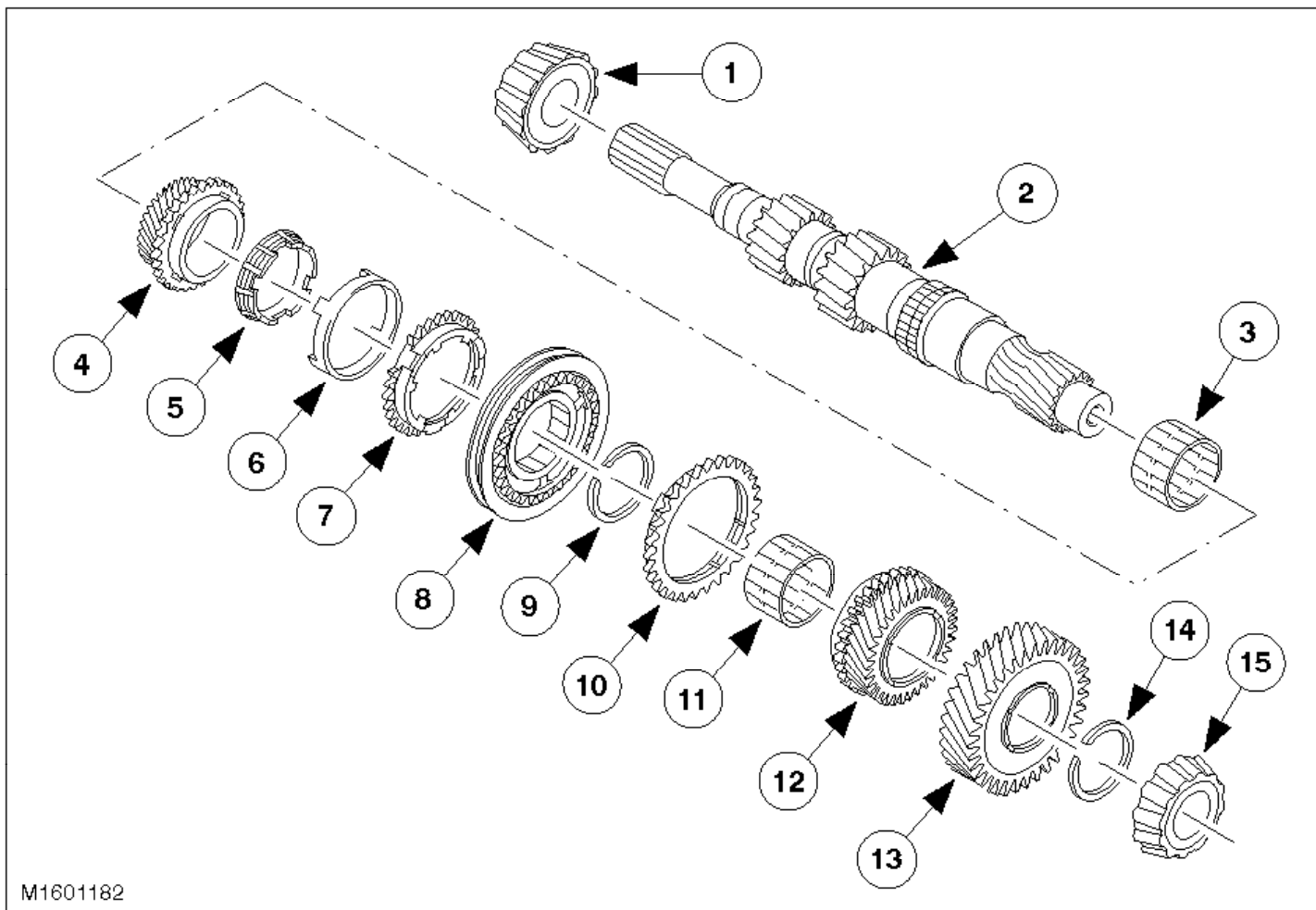

M1601182

Layout of the input shaft

Item	Description
------	-------------

1	Taper roller bearing, clutch end
2	Input Shaft
3	Needle roller bearing for 3rd gear wheel
4	3rd gear wheel
5	3rd gear inner synchroniser ring
6	3rd gear synchroniser cone
7	3rd gear outer synchroniser ring
8	3rd/4th gear synchroniser assembly
9	Circlip
10	4th gear synchroniser ring
11	Needle roller bearing for 4th gear
12	4th gear wheel
13	Fifth gear wheel
14	Circlip
15	Taper roller bearing, transmission end

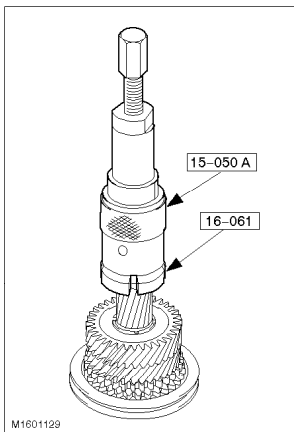

## Dismantle input shaft

Note:

For transmission repairs, always consult TSB No. 192/1996.

- 30. Pull off the taper roller bearing.

Note:

The taper roller bearing and gear wheel can be pressed off together (see following step).

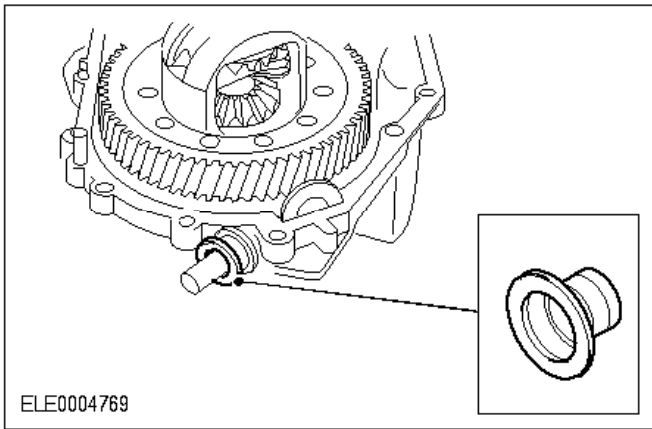

31. Press off the 5th gear wheel and the taper roller bearing.
- 1 Move the circlip upwards out of the annular groove up to the taper roller bearing.
  - 2 Press off the gear wheel together with the circlip and taper roller bearing.

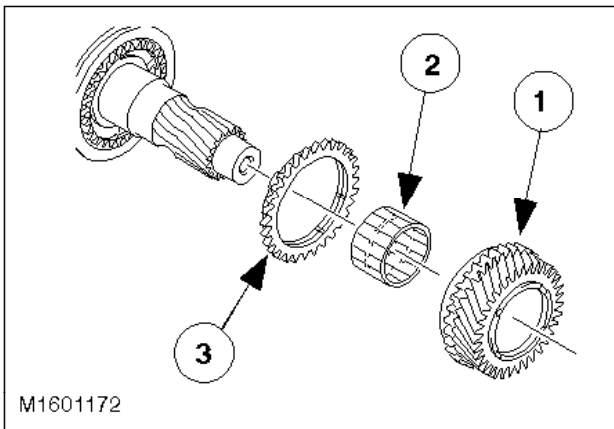

32. Remove the 4th gear wheel with the needle roller bearing and synchroniser ring.
- 1 Gear wheel
  - 2 Needle roller bearing
  - 3 Synchroniser ring

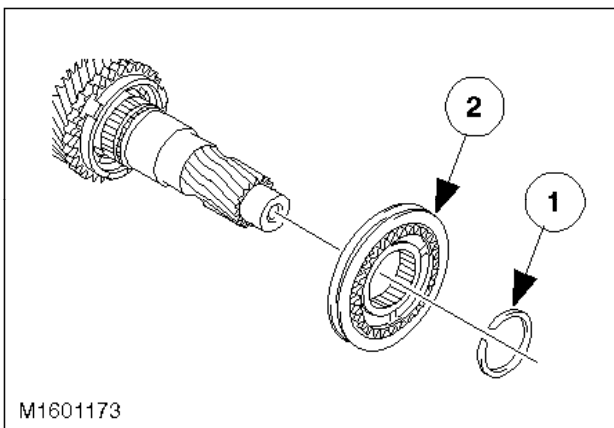

33. Detach the 3rd/4th gear synchroniser assembly.
- 1 Circlip
  - 2 Gear synchroniser

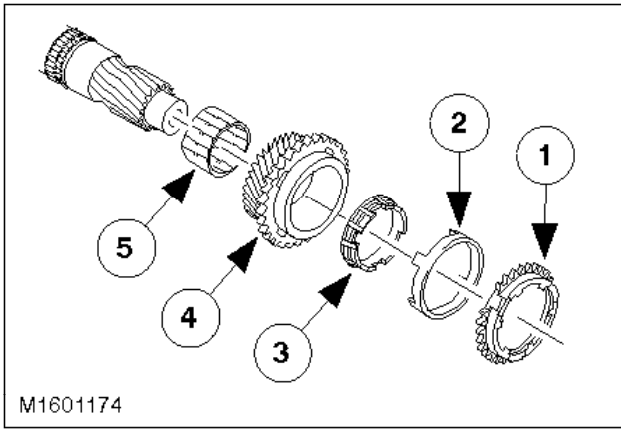

⌚ 34. Detach the 3rd gear wheel and double synchroniser.

- 1 Outer synchroniser ring
- 2 Synchroniser cone
- 3 Inner synchroniser ring
- 4 Gear wheel
- 5 Needle roller bearing

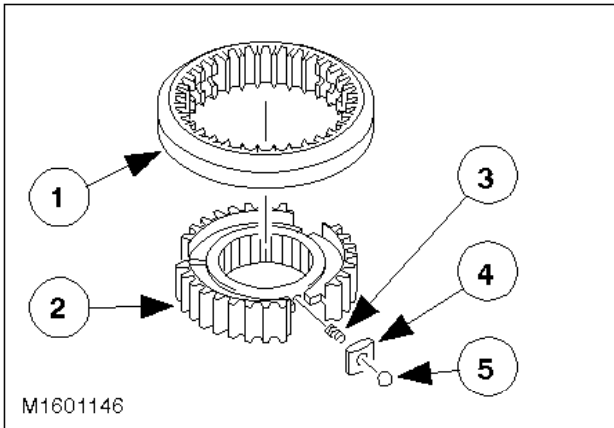

Note:

Mark the installation position of the selector ring.

⌚ 35. Dismantle the synchroniser clutches.



**WARNING:**

**CAREFULLY PULL THE SELECTOR RING OFF THE HUB OF THE GEAR SYNCHRONISER. THE DETENT BALLS ARE SPRING-LOADED.**

- 1 Selector ring
- 2 Gear synchroniser hub
- 3 Compression spring
- 4 Blocker bar
- 5 Detent ball



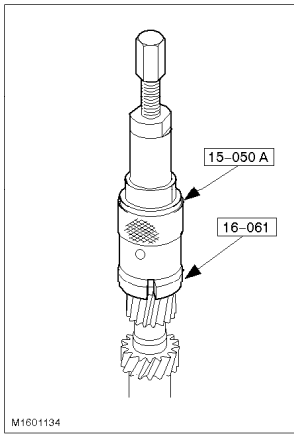

- 36. Pull the taper roller bearing off the input shaft.
- 37. General note.

**Note:**

From model year '95 a double synchroniser is installed for 1st, 2nd and 3rd gears. The layout and assembly of the single synchroniser for 3rd gear is identical to that for 4th gear. The steps described below refer to the double synchroniser. Refer to the Technical Data table for details of replacement synchroniser parts.



**CAUTION:**

**The inner synchroniser ring and the synchroniser cone must be handled with great care.**

The layout and assembly of the single synchroniser for 3rd gear is identical to that for 4th gear. The steps described below refer to the double synchroniser. Refer to the Technical Data table for details of replacement synchroniser parts.

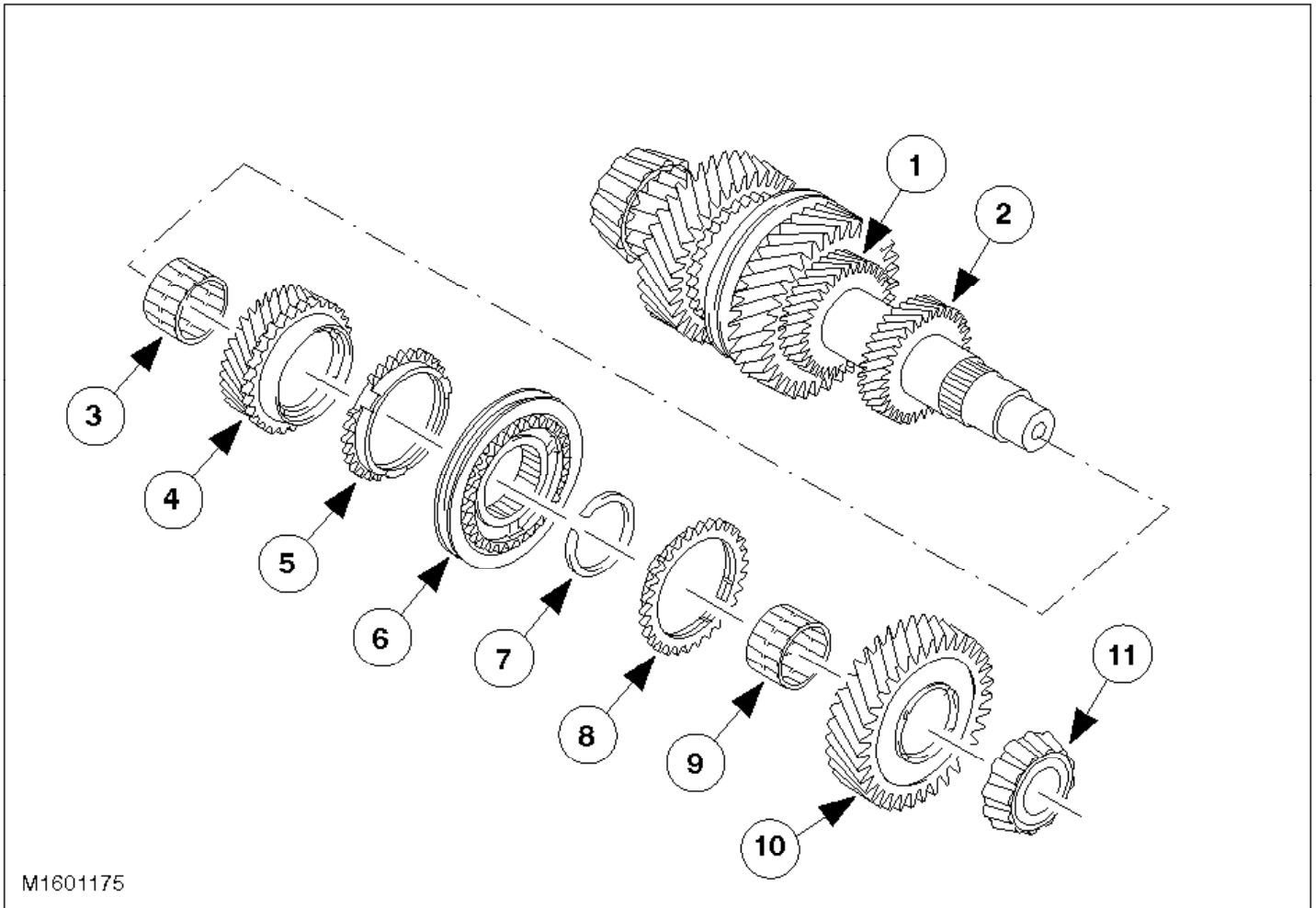

Layout of output shaft

Item	Description
1	3rd gear wheel
2	4th gear wheel
3	Needle roller bearing for 5th gear
4	Fifth gear wheel
5	Fifth gear synchroniser ring
6	5th/reverse gear synchroniser assembly
7	Circlip
8	Reverse synchroniser ring
9	Reverse needle roller bearing
10	Reverse gear wheel
11	Taper roller bearing

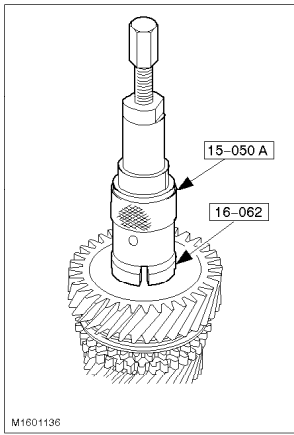

**Dismantle output shaft**

Note:

The reverse gear wheel and the taper roller bearing can be pressed off together.

- ☛ 38. Pull off the taper roller bearing.

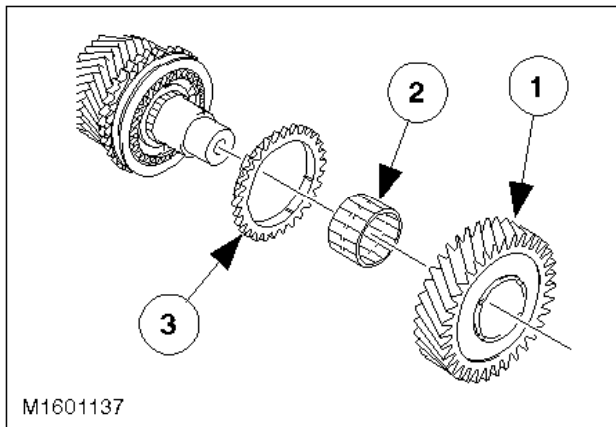

- ☛ 39. Detach the reverse gear assembly.

- 1 Gear wheel
- 2 Needle roller bearing
- 3 Synchroniser ring

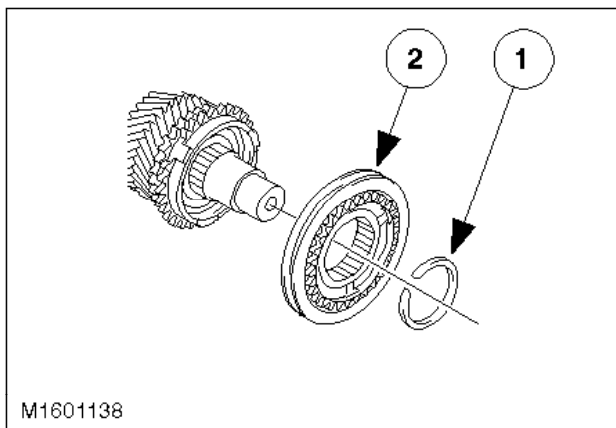

- ☛ 40. Remove the reverse/5th gear synchroniser assembly.

- 1 Circlip
- 2 Gear synchroniser

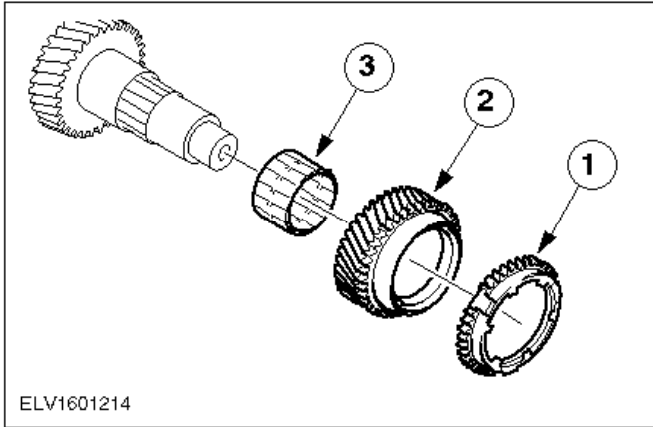

- ⦿ 41. Remove the 5th gear wheel together with the synchroniser ring and needle roller bearing.
- 1 Synchroniser ring
  - 2 Gear wheel
  - 3 Needle roller bearing

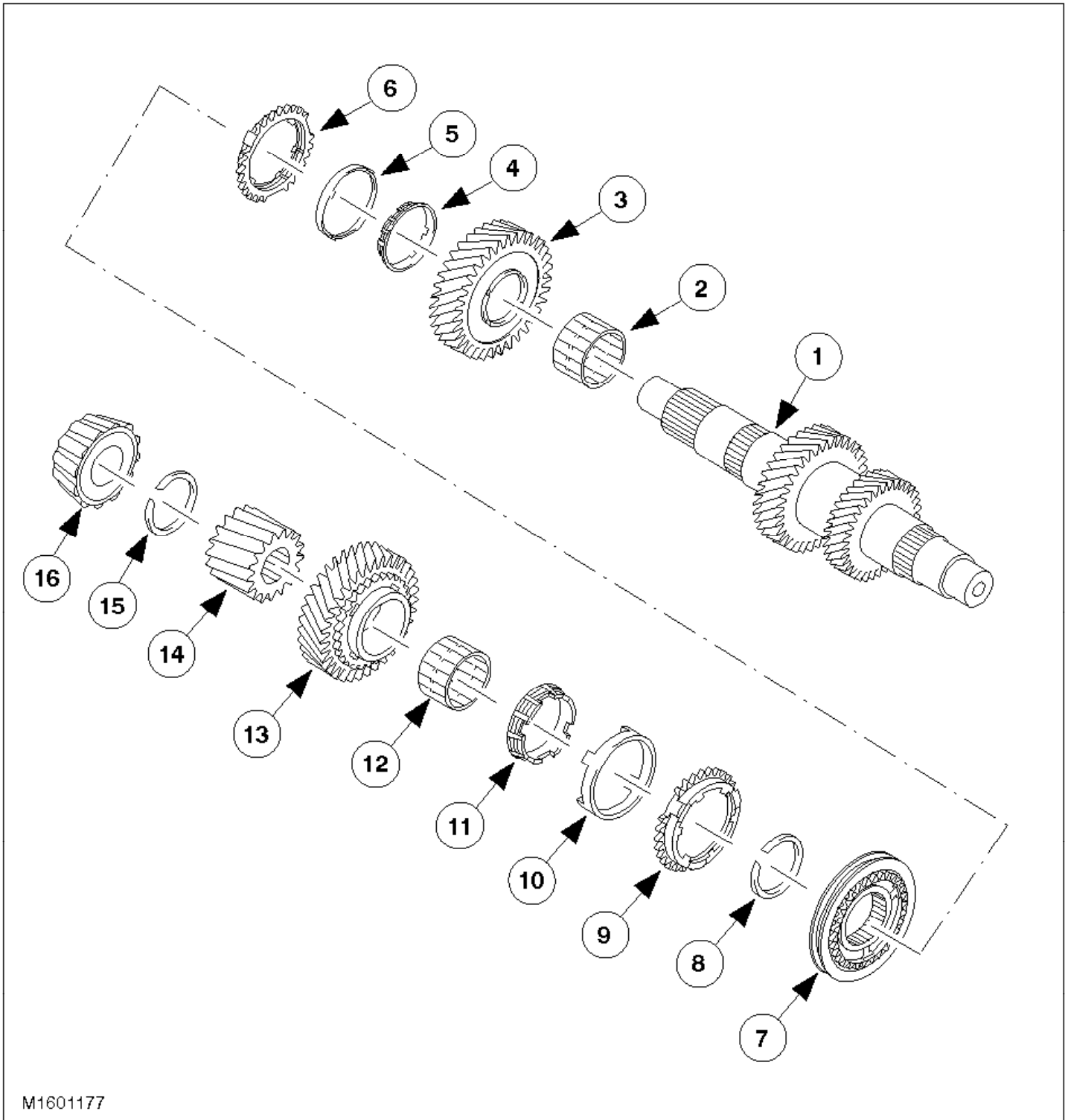

M1601177

Layout of output shaft

Item	Description
1	Output shaft
2	2nd gear needle roller bearing
3	2nd gear wheel
4	2nd gear inner synchroniser ring

5	2nd gear synchroniser cone
6	2nd gear outer synchroniser ring
7	1st/2nd gear synchroniser assembly
8	Circlip
9	1st gear outer synchroniser ring
10	1st gear synchroniser cone
11	1st gear inner synchroniser ring
12	1st gear needle roller bearing
13	First gear wheel
14	Output pinion
15	Circlip
16	Taper roller bearing

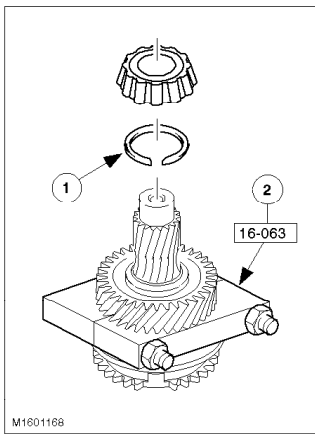

Ⓒ 42. Pull off the taper roller bearing at the clutch end.

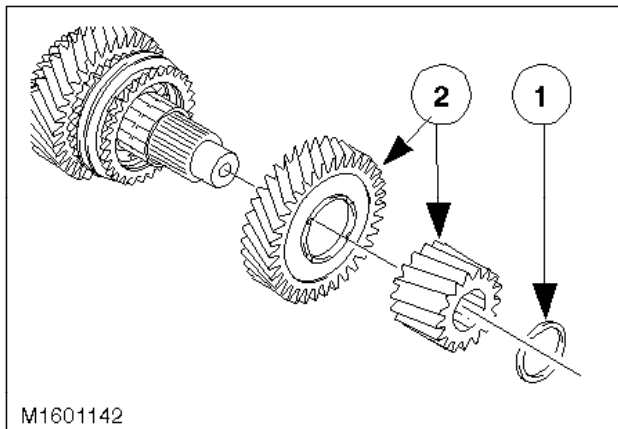

**⚠ CAUTION:**

**Mark the output pinion for reassembly. The output shaft and output pinion are a pair and can only be renewed together.**

- ☛ 43. Press off the output pinion together with the 1st gear wheel.
- 1 Circlip
  - 2 Pinion and 1st gear wheel

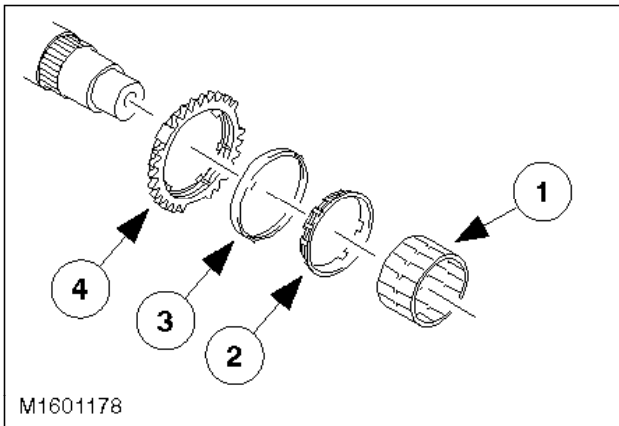

- ☛ 44. Remove the double synchroniser together with the needle roller bearing.
- 1 Needle roller bearing
  - 2 Inner synchroniser ring
  - 3 Synchroniser cone
  - 4 Outer synchroniser ring

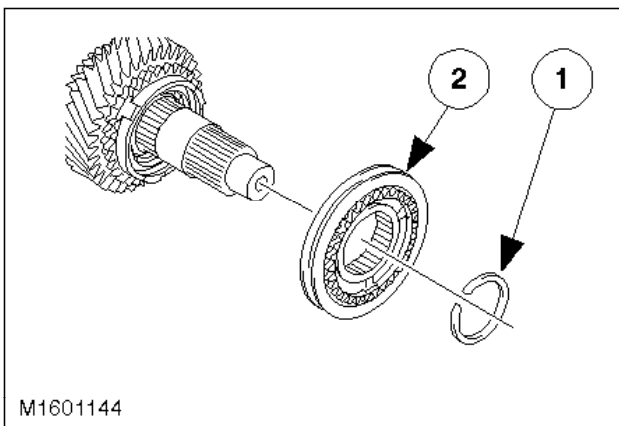

- ☛ 45. Detach the 1st/2nd gear synchroniser assembly.
- 1 Circlip
  - 2 Gear synchroniser

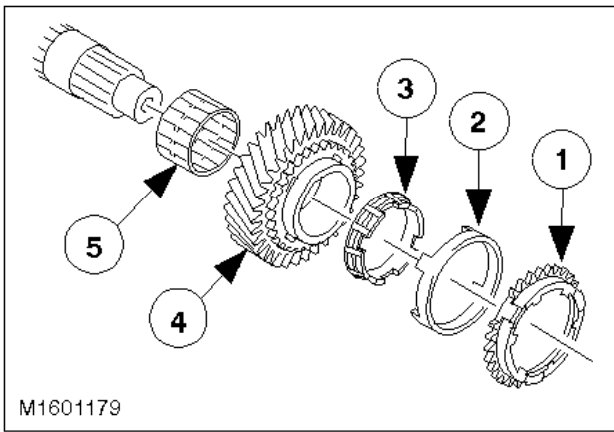

⌚ 46. Remove the 2nd gear wheel.

- 1 Outer synchroniser ring
- 2 Synchroniser cone
- 3 Inner synchroniser ring
- 4 2nd gear wheel
- 5 Needle roller bearing

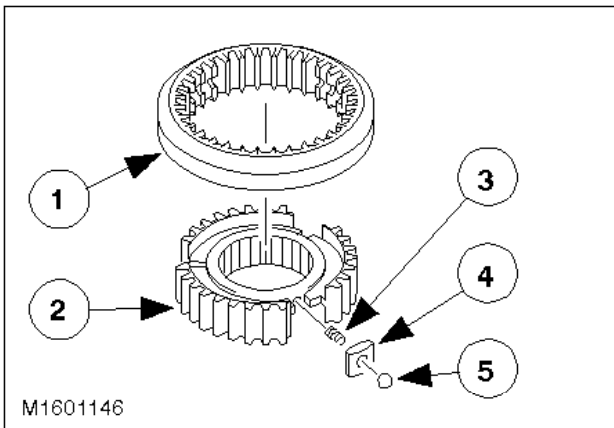

Note:  
Mark the installation position of the selector ring.

⌚ 47. Dismantle the synchroniser clutches.



**WARNING:**

**CAREFULLY PULL THE SELECTOR RING OFF THE GEAR SYNCHRONISER HUB. THE DETENT BALLS ARE SPRING-LOADED.**

- 1 Selector ring
- 2 Gear synchroniser hub
- 3 Compression spring
- 4 Blocker bar
- 5 Detent ball

**Assemble**

48. Carefully clean and check all parts before reassembly.





- 2 Locate the ball socket in position and tighten it.

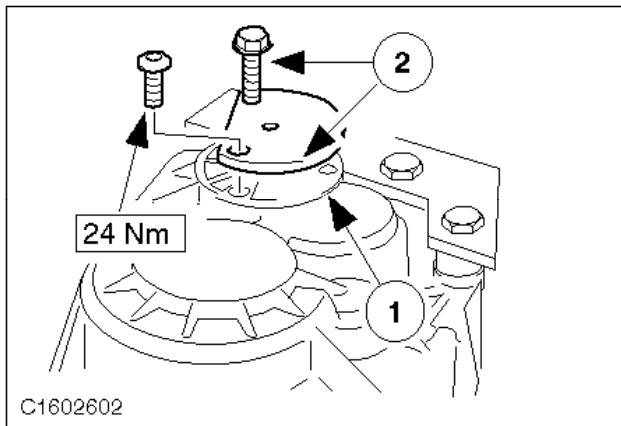

**Note:**

Heat the transmission housing with the hot air gun to a temperature of approx. 80°C.

- ⌚ 52. Install the reverse gear idler shaft.

- 1 Apply sealer (WSK-M2G348-A5) to the reverse gear idler shaft sealing face.
- 2 Locate the reverse gear idler shaft in position with the locating bolt and drive it in. Remove the locating bolt and screw in the original bolts.

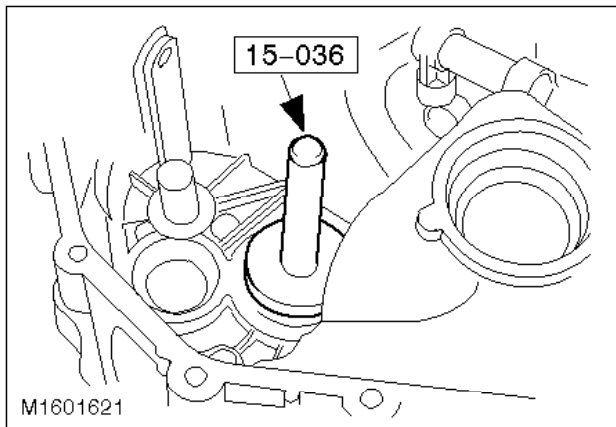

**Fit the bearing rings**

- ⌚ 53. Install the bearing rings on the transmission housing end.

- Heat the housing to approx. 80°C.
- Cool the bearing rings using a refrigerant spray and install them.



**CAUTION:**

The pressure applied must not exceed 15 kN.

**Note:**

Install using the press, do not drive it in.

- Bearing rings for:
- Input shaft using 15-036
- Output shaft using 15-036
- Differential using 14-024

54. Required shim thickness:

- Input shaft: 1,00 mm
- Output shaft: 1,00 mm
- Differential: 1,10 mm

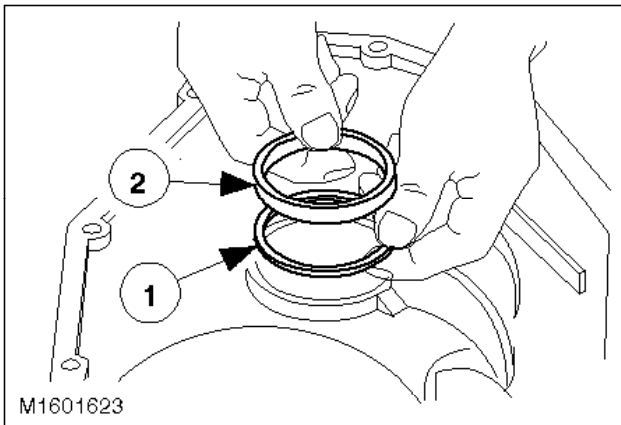

- ☞ 55. Install the measuring shims and bearing rings in the clutch-side housing section.
- Warm the housing to approx. 80°C.
  - Cool the bearing rings using a refrigerant spray.
  - 1 Insert the measuring shims.
  - 2 Insert the bearing rings.



**CAUTION:**

**The pressure applied must not exceed 15 kN.**

Note:

Install using the press, do not drive in.

- Bearing rings for:
- Input shaft with 14-010
- Output shaft with 15-036
- Differential with 14-024

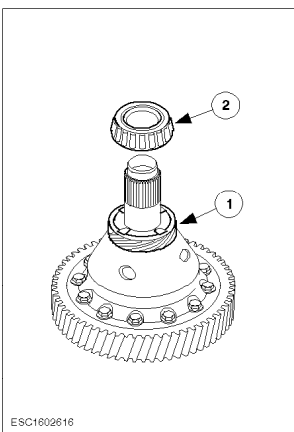

**Assemble the differential**



**CAUTION:**

**Do not damage the bearing cage when pressing it on.**

- ☞ 56. Fit the taper roller bearing.

Note:

The speedometer worm gear must engage in the housing recess.

- 1 Install the worm gear.
- 2 Press on the taper roller bearing using a suitable length of tube.

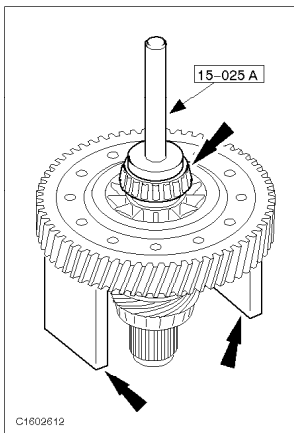

57. Install the taper roller bearing (on the crown wheel side).



**CAUTION:**

**Do not use the taper roller bearing as a support.**

- Support the differential by the crown wheel.
- Press on the taper roller bearing.

### Assemble input shaft

Note:

Do not oil the taper roller bearings that are to be reused. New taper roller bearings can be fitted unoiled.

58. Carefully clean and check all parts before reassembly. Apply transmission fluid (ESD-M2C186-A) to all sliding parts.

Note:

From model year '95 a double synchroniser is installed for 1st, 2nd and 3rd gear.



**CAUTION:**

**The inner synchroniser ring and the synchroniser cone must be handled with great care.**



**CAUTION:**

**Place the double synchronisers in an oil bath (ESD-M2C186-A) before installation.**

The layout and assembly of the single synchroniser for 3rd gear is identical to that for 4th gear. The steps described below refer to the double synchroniser. Refer to the Technical Data table for details of replacement synchroniser parts.

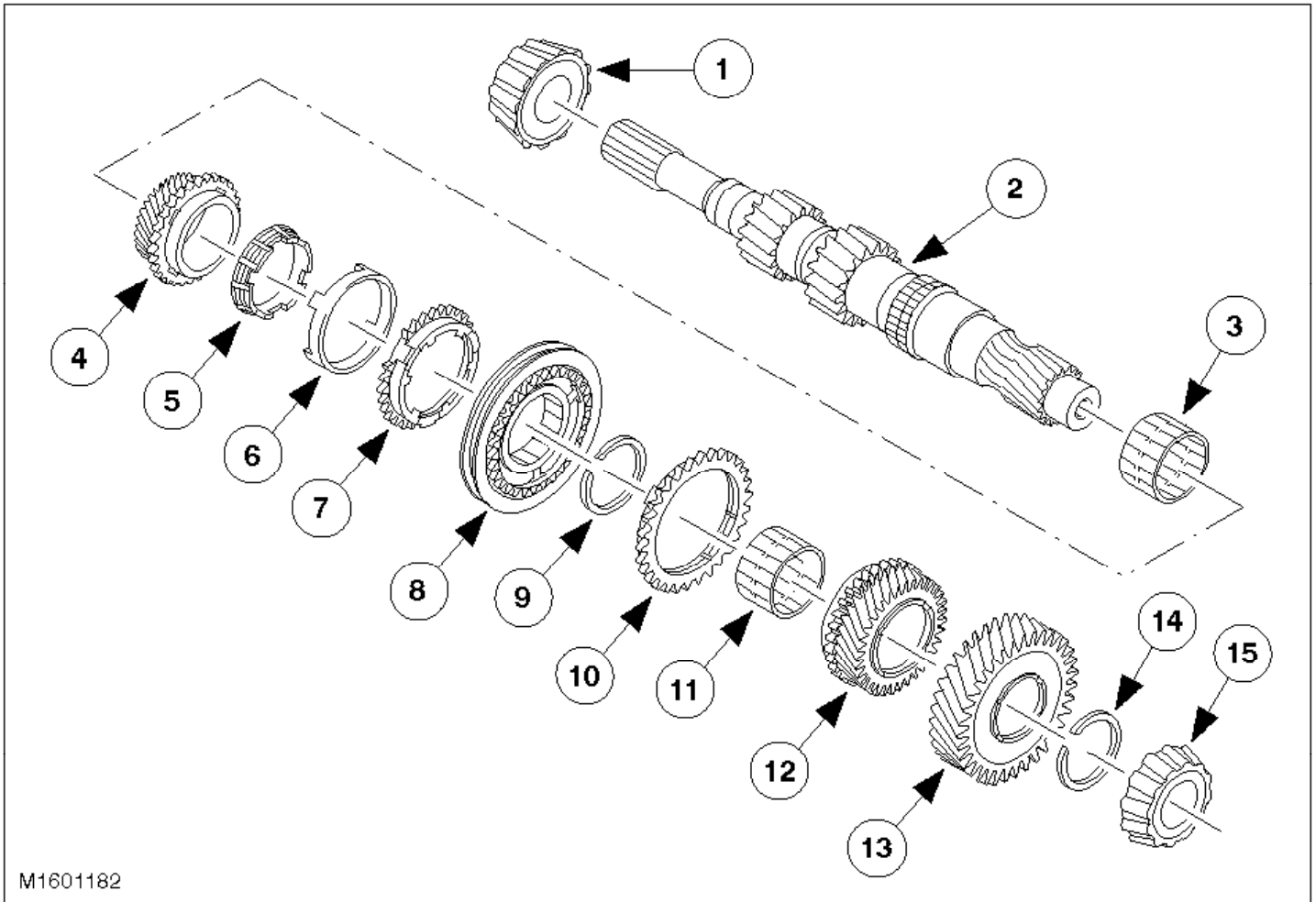

M1601182

Layout of the input shaft

Item	Description
1	Taper roller bearing
2	Input shaft
3	3rd gear needle roller bearing
4	3rd gear wheel
5	3rd gear inner synchroniser ring
6	3rd gear synchroniser cone
7	3rd gear outer synchroniser ring
8	3rd/4th gear synchroniser assembly
9	Circlip
10	Fourth gear synchroniser ring
11	4th gear needle roller bearing
12	4th gear wheel

13	Fifth gear wheel
14	Circlip
15	Taper roller bearing

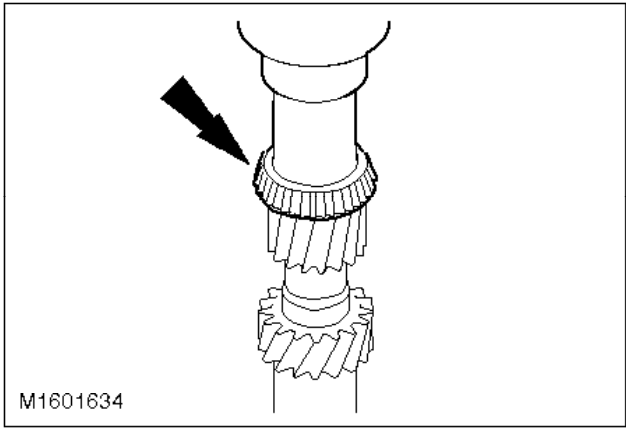

- ⦿ 59. Press on the taper roller bearing on the clutch side.  
Press the taper roller bearing on using a suitable length of tube.

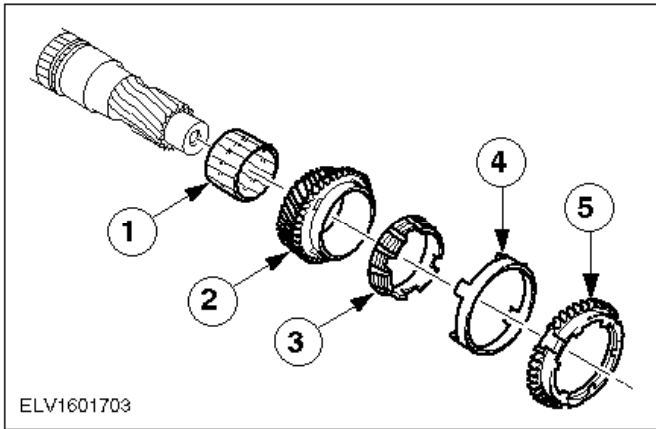

Note:  
See previous step.

- ⦿ 60. Fit the 3rd gear wheel.
- 1 Needle roller bearing
  - 2 3rd gear wheel
  - 3 Inner synchroniser ring
  - 4 Synchroniser cone
  - 5 Outer synchroniser ring

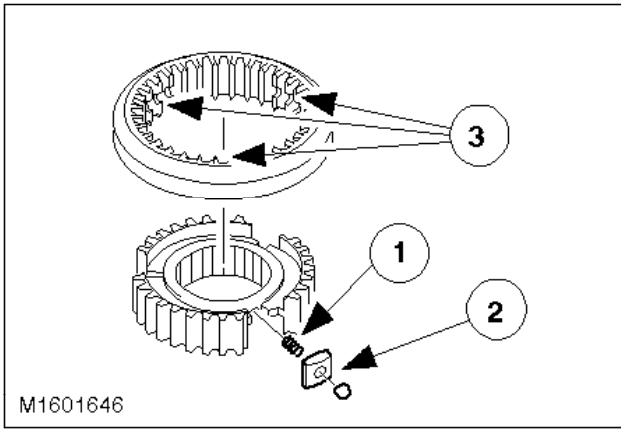

**Note:**

Installation position marking. Refer also to next step.

- 61. Assemble the 3rd/4th gear synchroniser.

- 1 Insert the compression springs.
- 2 Insert the blocker bar and the gear synchroniser hub detent balls next to the spring.
- 3 Align the selector ring correctly and push it on.

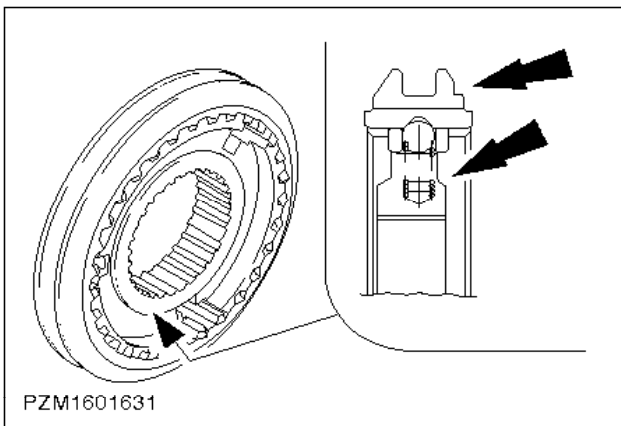

- 62. The installation position of the synchroniser clutch.

**Note:**

The annular groove of the selector ring and the small collar on the synchroniser hub must face in the same direction.

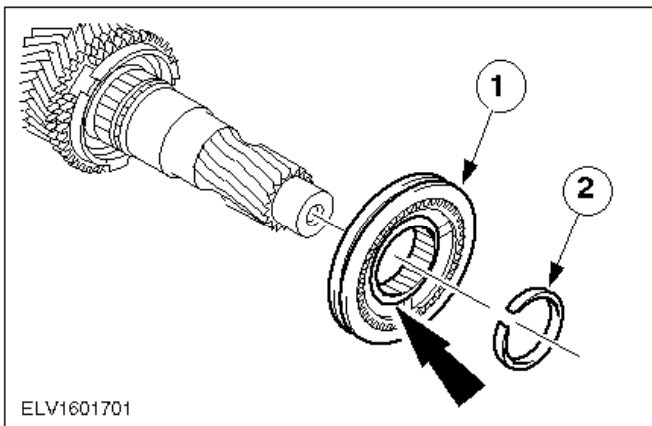

63. Install the 3rd/4th gear synchroniser.

Note:

The large collar on the synchroniser hub must face outwards.

- 1 Install the gear synchroniser assembly.
- 2 Fit a new circlip.

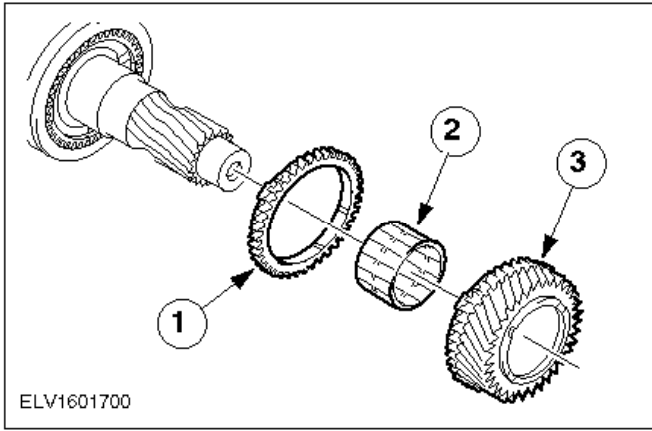

64. Fit the 4th gear wheel.

- 1 Synchroniser ring
- 2 Needle roller bearing
- 3 Gear wheel

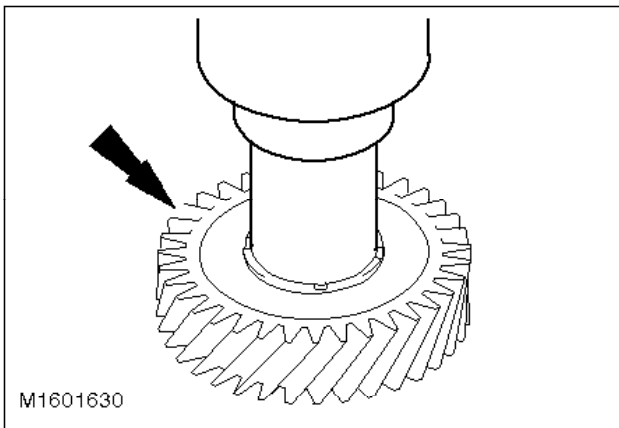

65. Press on the 5th gear wheel.

- Press on the gear wheel using a suitable length of tube.
- Fit a new circlip.



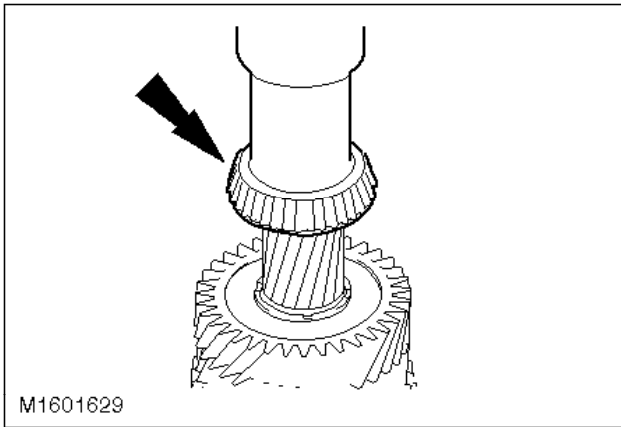

- ⦿ 66. Press on the taper roller bearings on the transmission and clutch side (transmission-side taper roller bearing shown).

Press on the taper roller bearings with a suitable length of tube.

### Assemble output shaft

Note:

Do not oil taper roller bearings that are to be reused. Install new taper roller bearings unoled.

67. Carefully clean and check all components before reassembly and lubricate with transmission fluid (ESDM-2C186-A).

Note:

From model year '95 a double synchroniser is installed for 1st, 2nd and 3rd gears.



**CAUTION:**

**The inner synchroniser ring and the synchroniser cone must be handled with great care.**



**CAUTION:**

**Place the double synchronisers in an oil bath (ESD-M2C186-A) before installation.**

The layout and assembly of the single synchroniser for 3rd gear is identical to that for 4th gear. The steps described below refer to the double synchroniser. Refer to the Technical Data table for details of replacement synchroniser parts.

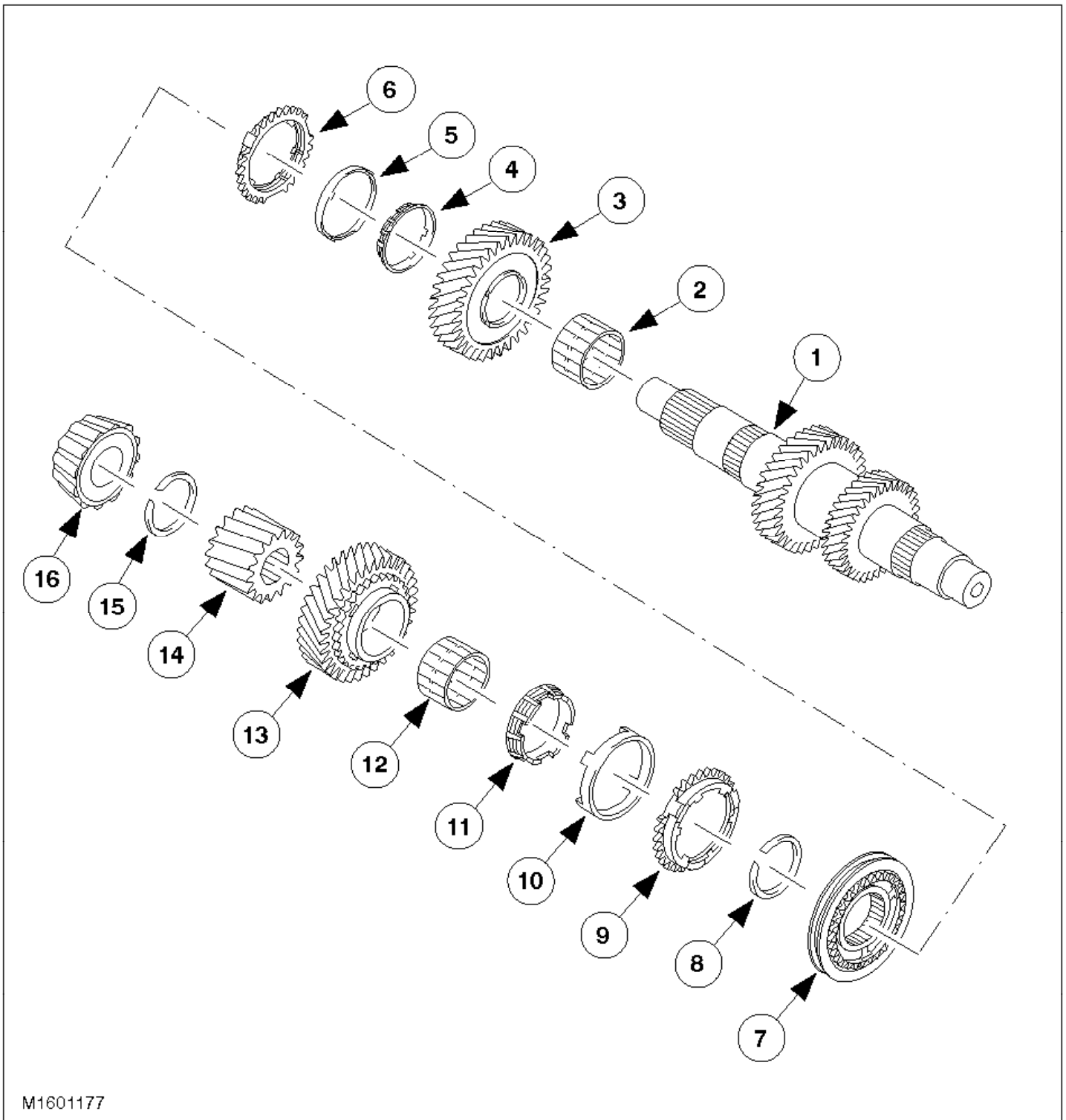

Layout of output shaft

Item	Description
1	Output shaft
2	2nd gear needle roller bearing
3	2nd gear wheel
4	2nd gear inner synchroniser ring

5	2nd gear synchroniser cone
6	2nd gear outer synchroniser ring
7	1st/2nd gear synchroniser assembly
8	Circlip
9	1st gear outer synchroniser ring
10	1st gear synchroniser cone
11	1st gear inner synchroniser ring
12	1st gear needle roller bearing
13	First gear wheel
14	Output pinion
15	Circlip
16	Taper roller bearing

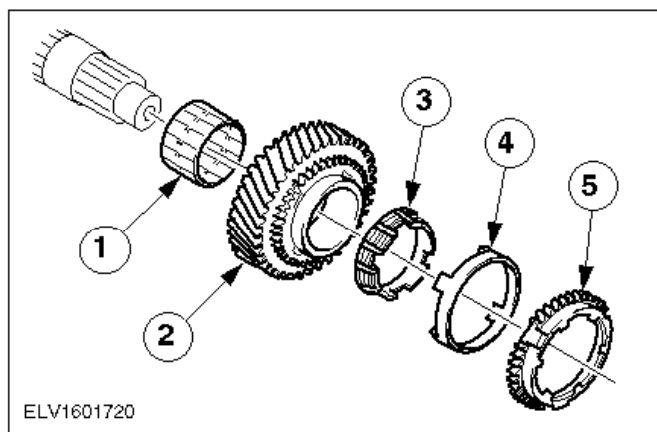

Note:

Refer to previous step.

⦿ 68. Fit the 2nd gear wheel.

- 1 Needle roller bearing
- 2 2nd gear wheel
- 3 Inner synchroniser ring
- 4 Synchroniser cone
- 5 Outer synchroniser ring

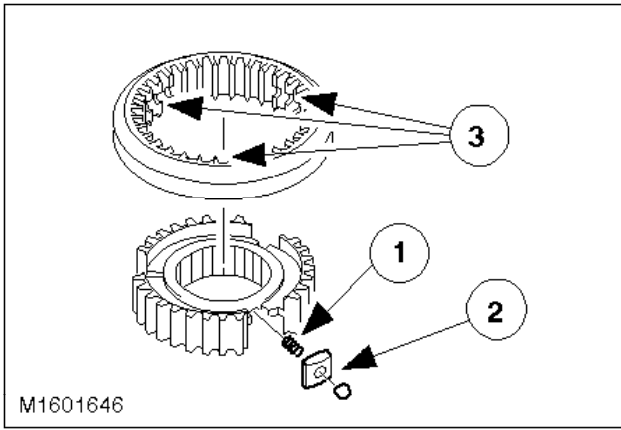

**Note:**

Installation position marking. Refer also to next step.

69. Assemble the 1st/2nd gear synchroniser.

- 1 Insert the compression springs.
- 2 Fit the blocker bar and the gear synchroniser hub detent balls next to the spring.
- 3 Align the selector ring correctly and push it on.

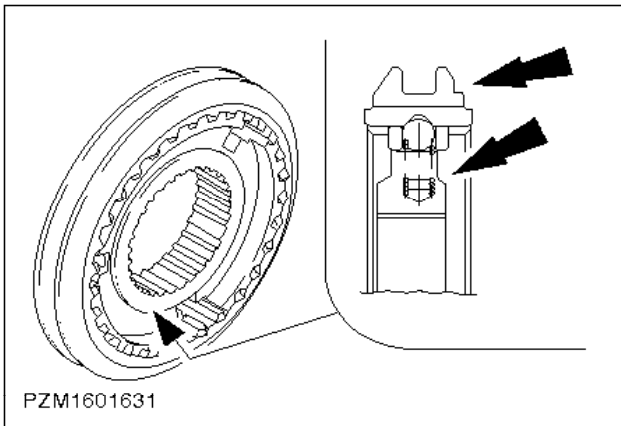

70. Installation position of the 1st/2nd gear synchroniser

**Note:**

The annular groove of the selector ring and the small collar on the synchroniser hub must face in the same direction.

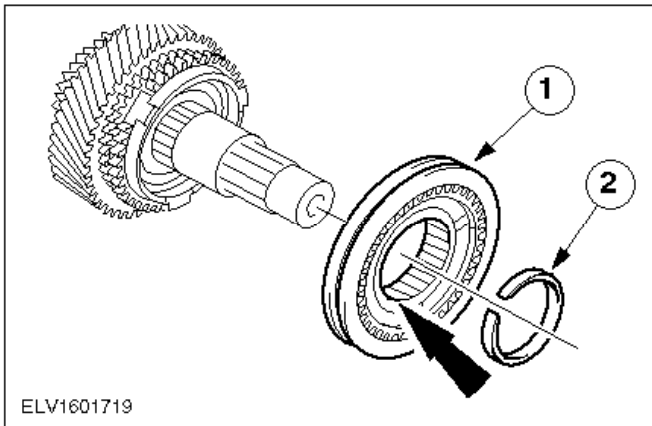

Note:

The small collar on the synchroniser hub must face outwards.

- ☛ 71. Fit the 1st/2nd gear synchroniser.
  - 1 Fit the synchroniser assembly.
  - 2 Fit a new circlip.

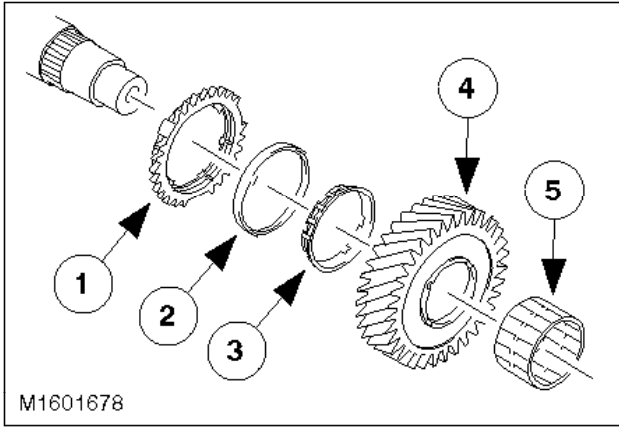

Note:

Refer to previous step.

- ☛ 72. Fit the 1st gear wheel together with the double synchroniser.
  - 1 Outer synchroniser ring
  - 2 Synchroniser cone
  - 3 Inner synchroniser ring
  - 4 First gear wheel
  - 5 Needle roller bearing

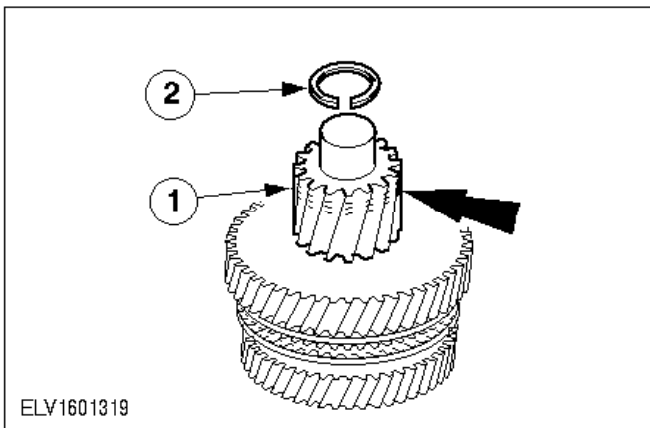

**CAUTION:**

**The output pinion can only be fitted on to the splines in one position. Fit the output pinion with the mark facing upwards.**

- ☛ 73. Press on the output pinion.
  - 1 Press on the output pinion with a suitable length of tube and a press.
  - 2 Fit a new circlip.

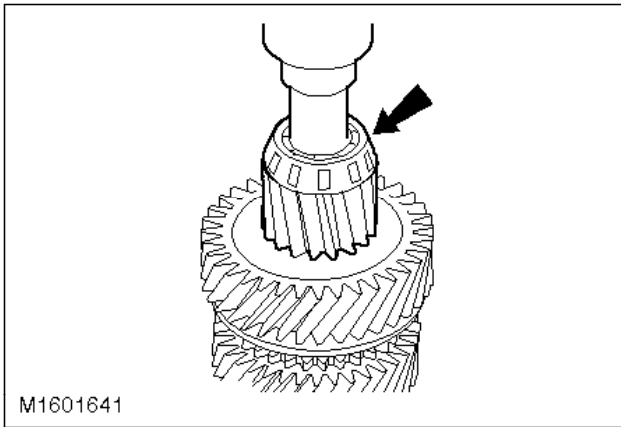

- 74. Press on the taper roller bearing.

Press on the taper roller bearing using a suitable length of tube and a press.

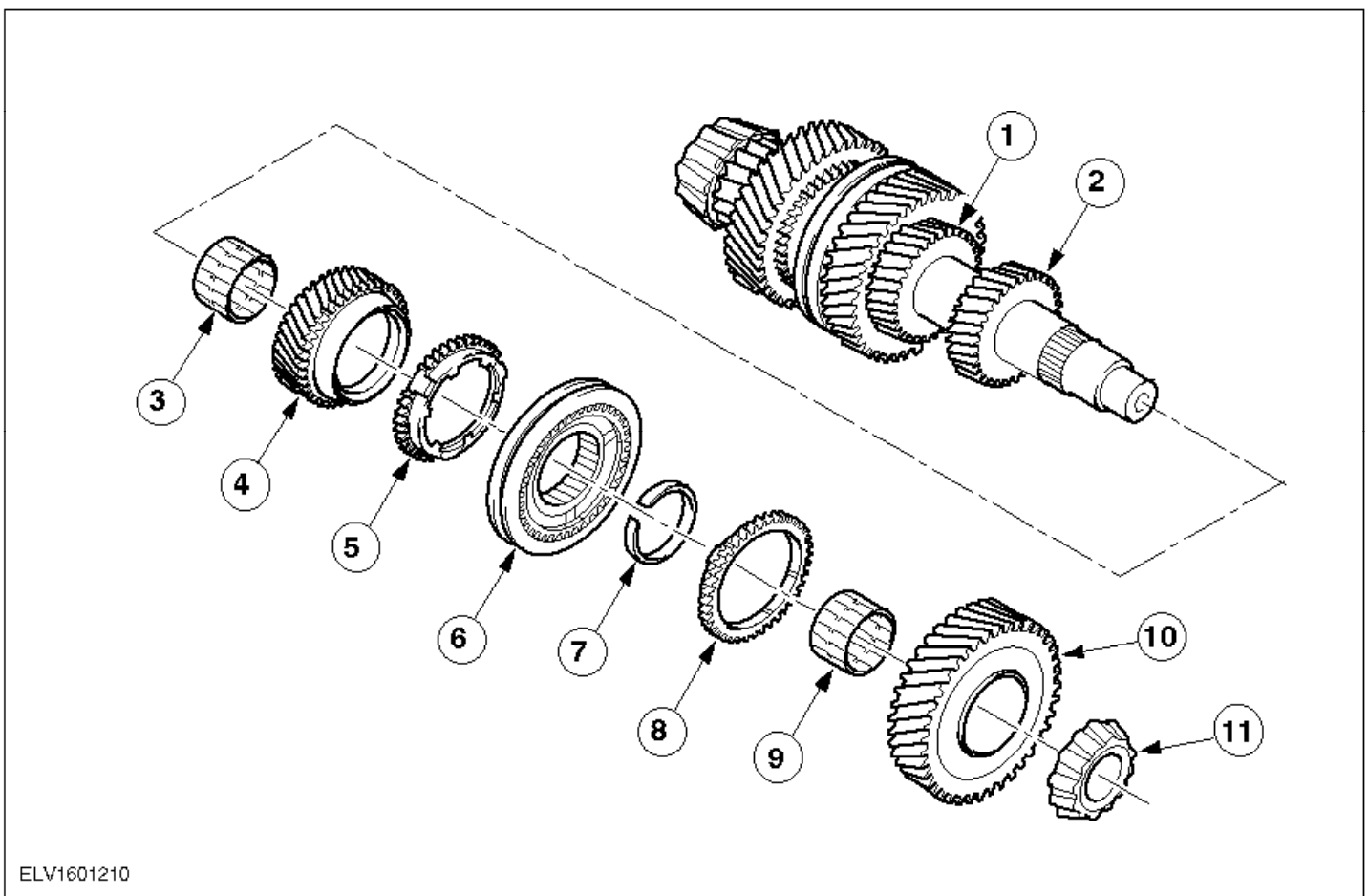

Layout of output shaft

Item	Description
1	3rd gear wheel
2	4th gear wheel
3	5th gear needle roller bearing
4	Fifth gear wheel

5	Fifth gear synchroniser ring
6	5th/reverse gear synchroniser assembly
7	Circlip
8	Reverse gear synchroniser ring
9	Reverse gear needle roller bearing
10	Reverse gear wheel
11	Taper roller bearing

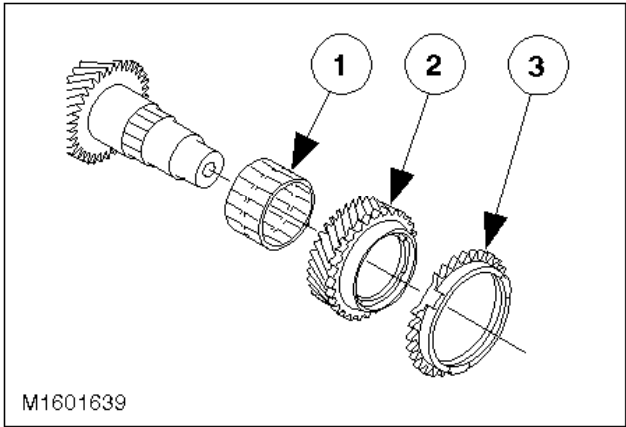

75. Fit the 5th gear wheel.

- 1 Needle roller bearing
- 2 Fifth gear wheel
- 3 Synchroniser ring

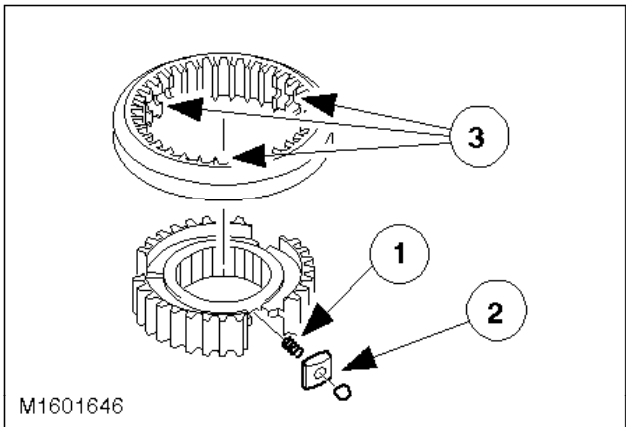

Note:

Installation position marking. Refer also to next step.

76. Assemble the 5th/reverse gear synchroniser.

- 1 Insert the compression springs.
- 2 Fit the blocker bar and the detent balls next to the spring.
- 3 Align the selector ring correctly and push it on.

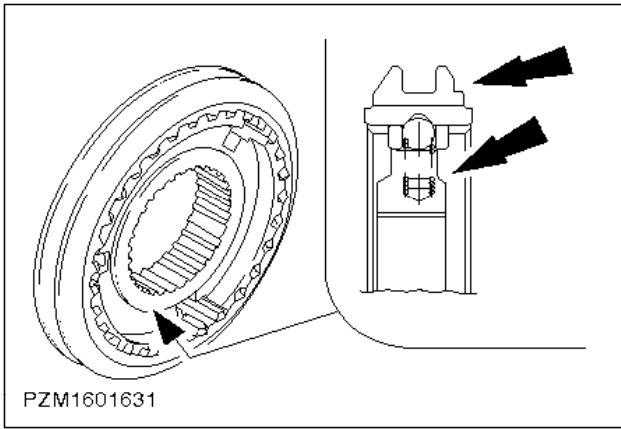

- 77. The installation position of the synchroniser clutch.

Note:

The annular groove of the selector ring and the small collar on the synchroniser hub must face in the same direction.

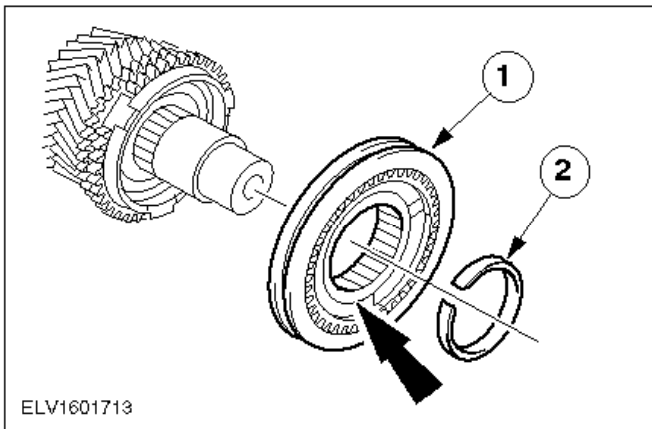

Note:

The synchroniser hub must be fitted with the small collar and the annular groove facing outwards.

- 78. Fit the 5th/reverse gear synchroniser.

- 1 Fit the synchroniser assembly.
- 2 Fit a new circlip.

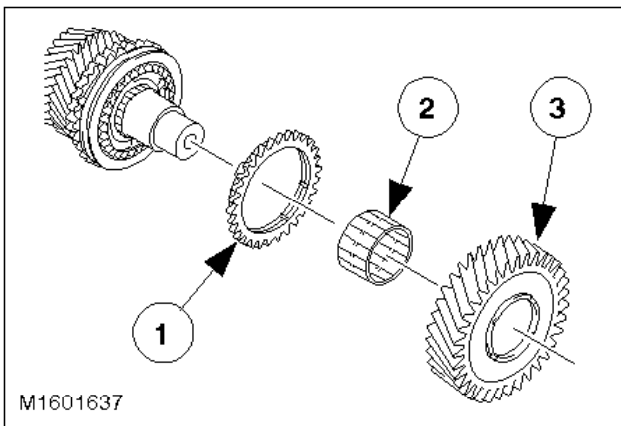



⌚ 79. Fit the reverse gear wheel assembly.

- 1 Synchroniser ring
- 2 Needle roller bearing
- 3 Reverse gear wheel

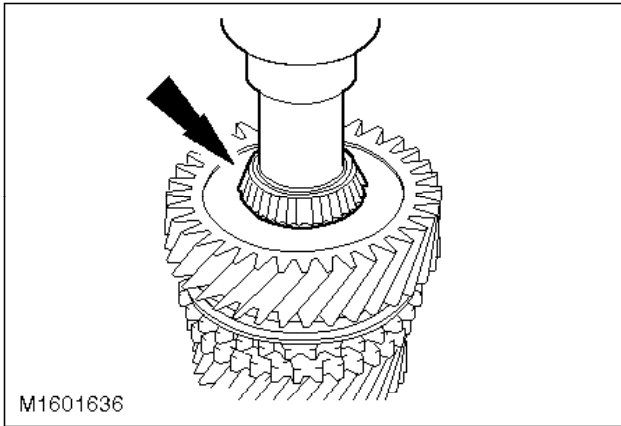

⌚ 80. Press on the taper roller bearing.

Press on the taper roller bearing using a suitable length of tube and a press.

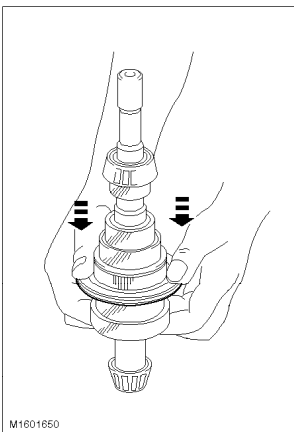

**Measure the shims.**



**CAUTION:**

**Do not oil taper roller bearings that are to be reused. Install new taper roller bearings unoled.**

⌚ 81. Install the input and output shafts in the transmission housing.

- Engage 4th gear.
- Install the input and output shafts together in the transmission housing.

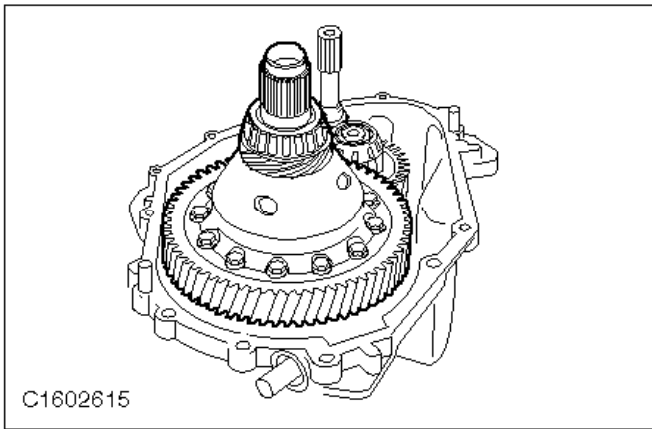

Note:

Do not oil taper roller bearings that are to be reused. Install new taper roller bearings unoled.

- 82. Install the differential.

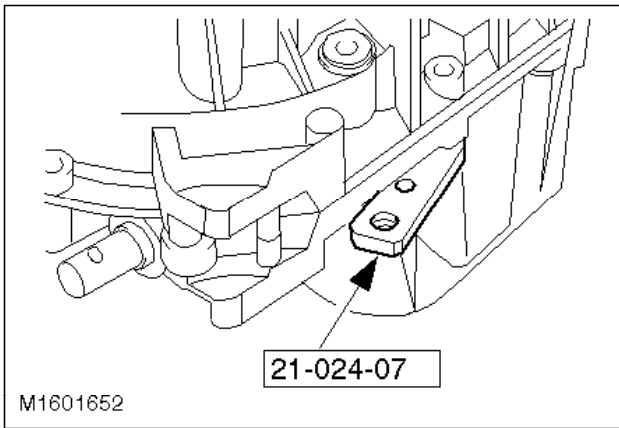

Note:

The mating face must be absolutely clean.

- 83. Fit the clutch-side transmission housing half.

Attach the special tool with the longer bolt.

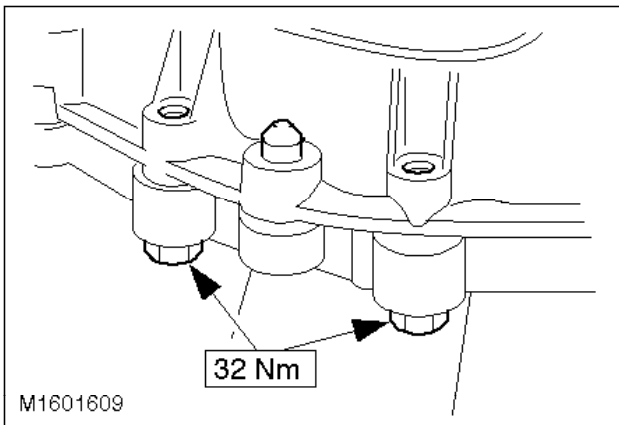

- 84. Tighten the clutch-side transmission housing half evenly (16 bolts).

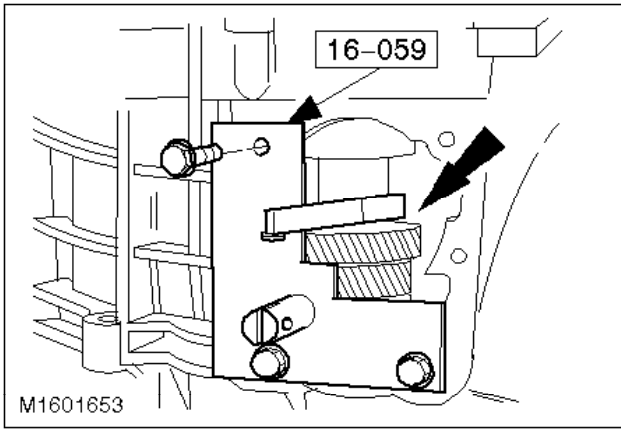

- 85. Mount the special tool.

Fit the measuring bar to the 4th gear wheel.

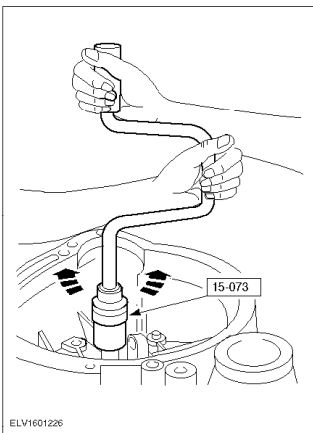

- 86. Prepare the input shaft for measurement.

Turn the input shaft approx. 20 times back and forth to settle the bearings.

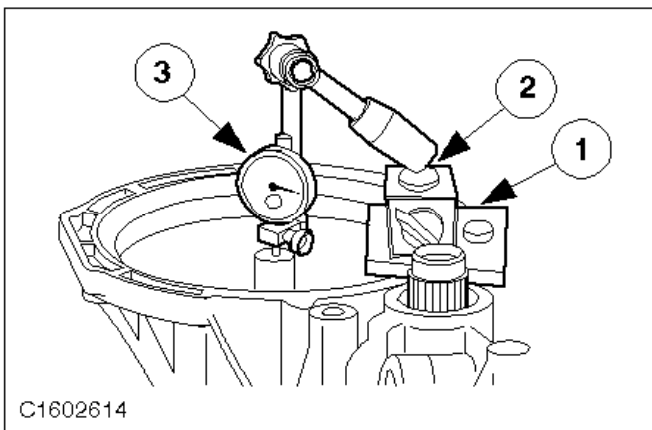

- 87. Fit the dial gauge.

- 1 Fit a steel mounting plate (e.g. 21-146) to the transmission.
- 2 Install the magnetic fixture.
- 3 Set the dial gauge with 1 mm preload to "0".

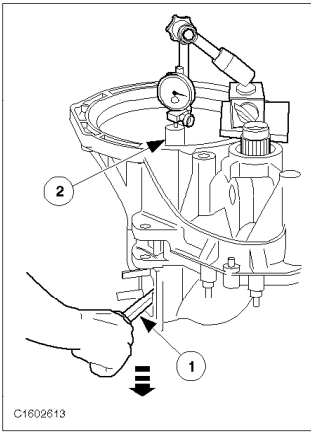

**Note:**

Carry out sub-operations 87., 88. and 89. three times and calculate the average measurement.

☛ 88. Measure the input shaft end float

- 1 Raise the input shaft using the lever.
  - 2 Make a note of the result (e.g. 0,22 mm)
- Example: 0,22 mm + 0,23 mm + 0,21 mm divided by 3 = 0,22 mm.

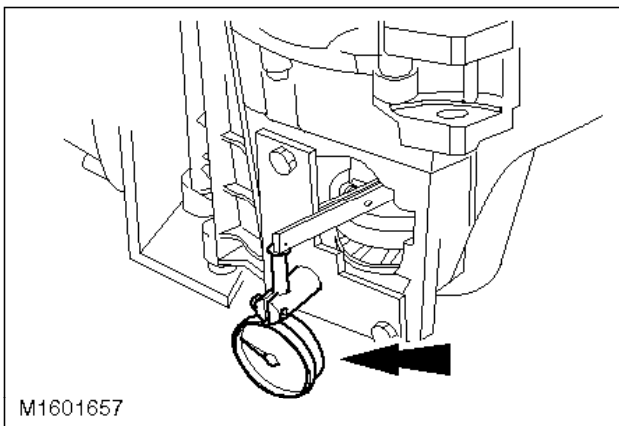

☛ 89. Prepare the output shaft for measurement.

- Turn the output shaft approx. 20 times back and forth to settle the bearings (refer to previous step for input shaft).
- Fit the dial gauge.
- Set the dial gauge with 1 mm preload to "0".

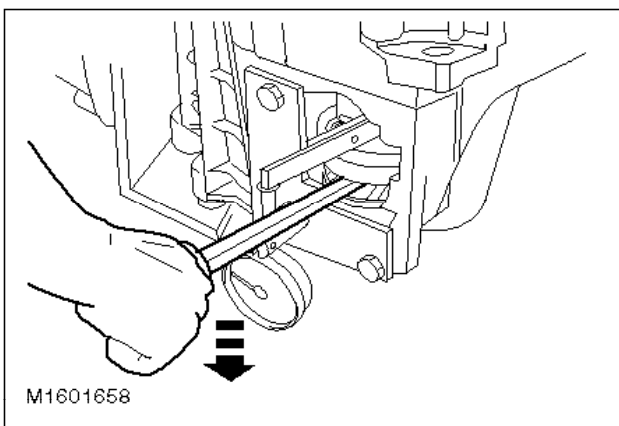

90. Measure the output shaft end float.

Note:

Carry out sub-operations 90. and 91. three times and calculate the average measurement.

- Raise the output shaft using the lever and make a note of the result, e.g. 0,32 mm.
- Example: 0,32 mm + 0,34 mm + 0,33 mm divided by 3 = 0,33mm.

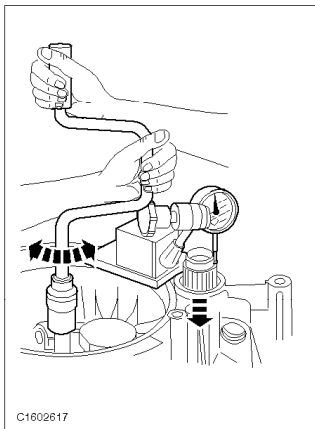

91. Prepare the differential for measuring.

- Turn the output shaft 20 times back and forth and press down the differential at the same time.
- Fit the dial gauge, preload it by 1 mm and zero it.

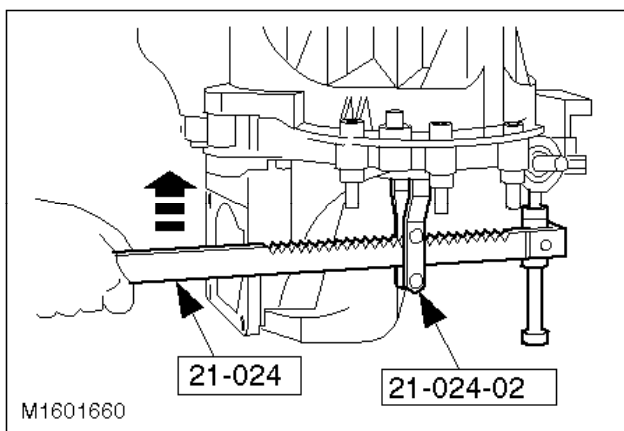

92. Measure the differential end float.

Note:

Carry out the above steps three times and calculate the average value.

- Lift the differential using the special tool and make a note of the result, e.g. 0,34 mm
- Example: 0,34 mm + 0,36 mm + 0,37 mm divided by 3 = 0,36 mm.

Measure required thickness of shim (dimensions in mm)

Description	Input Shaft	Output shaft	Differential
Measuring shim: mm	1,00	1,00	1,10
End float (for example)	+ 0,22	+ 0,33	+ 0,36
Pretensioning value	- - -	+ 0,13	+ 0,33

End float value	- 0,05	- - -	- - -
Required thickness of shim	= 1,17	= 1,46	= 1,79

93. Remove the bearing rings again.

Remove the bearing rings from the:  
input shaft, output shaft and differential as described in previous steps.

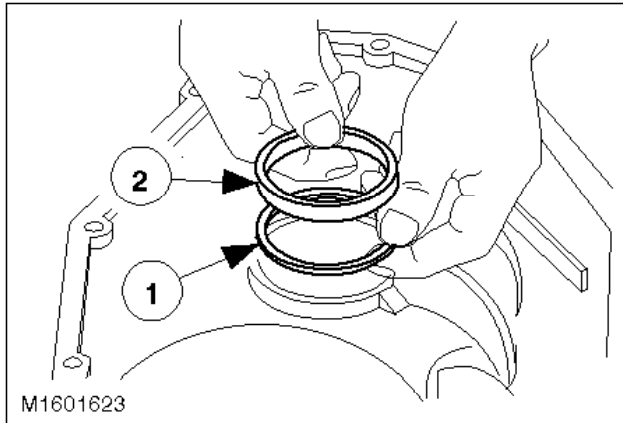

94. Install the shims and the bearing rings.

- 1 Install the shims of the required thickness.
- 2 Install the bearing rings for the:  
input shaft, output shaft and differential as described below.

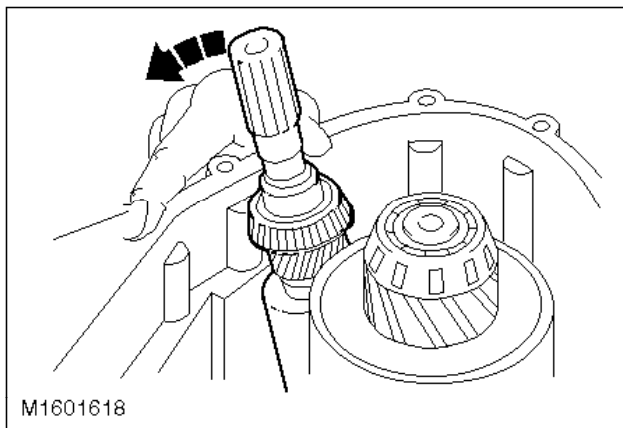

Note:

Oil the taper roller bearings.

95. Install the input and output shafts together.

Swivel the input shaft to one side and install the reverse idler gear (refer to next step for installation sequence).

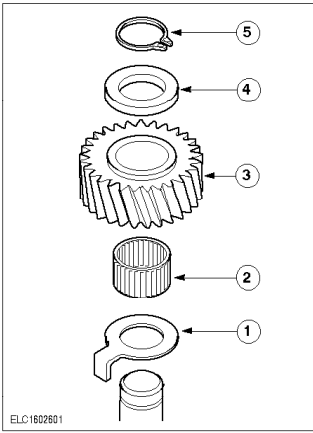

🔩 96. Fit the reverse gear idler.

- 1 Lower thrust washer
- 2 Needle roller bearing
- 3 Reverse gear idler
- 4 Upper thrust washer
- 5 Circlip

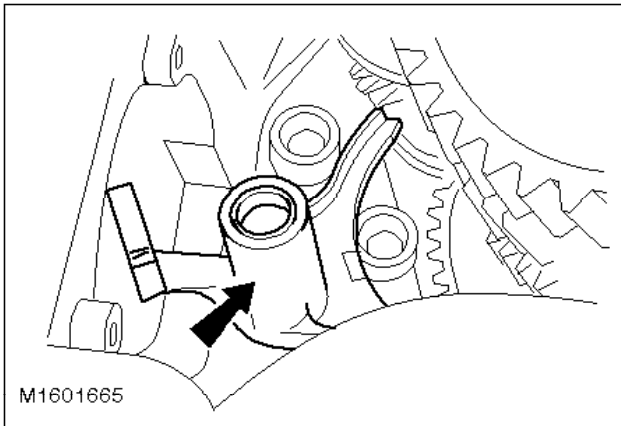

🔩 97. Fit the selector fork.

- Put the 4th gear selector ring in neutral.
- Fit the 5th/reverse gear selector fork and swivel it to one side.

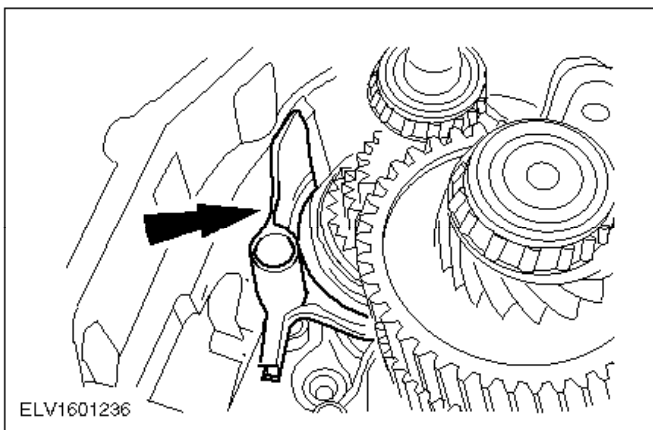

🔩 98. Fit the 3rd/4th gear selector fork.

Move the 5th/reverse gear selector fork back into position.

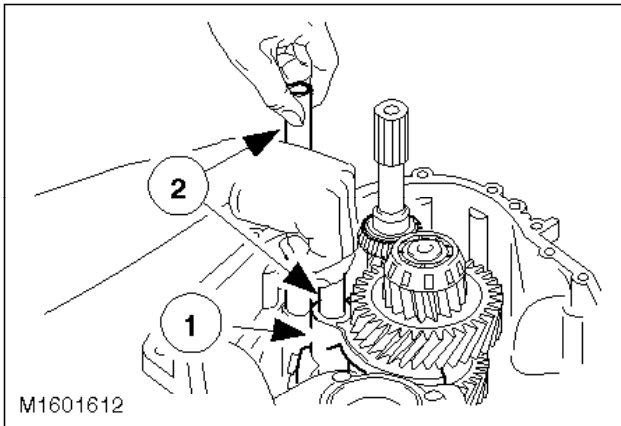

99. Install the 1st/2nd gear selector fork and rods.

Note:

When correctly positioned, all the selector rods are the same height.

- 1 Fit the selector fork.
- 2 Insert the shift rod.

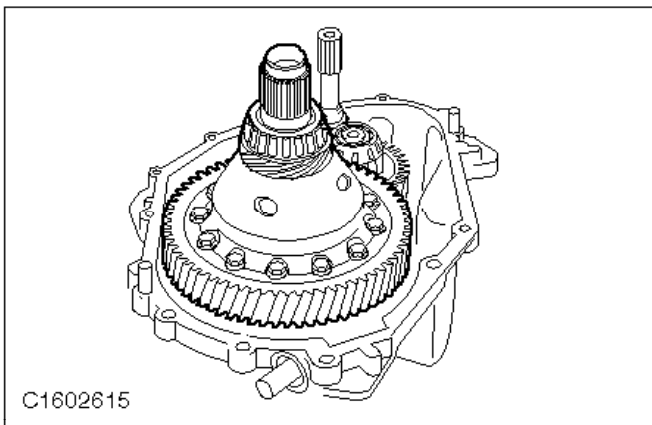

100. Install the differential.

- 1 Locate the differential in position.
- 2 Install the clean magnetic disc in the depression provided.

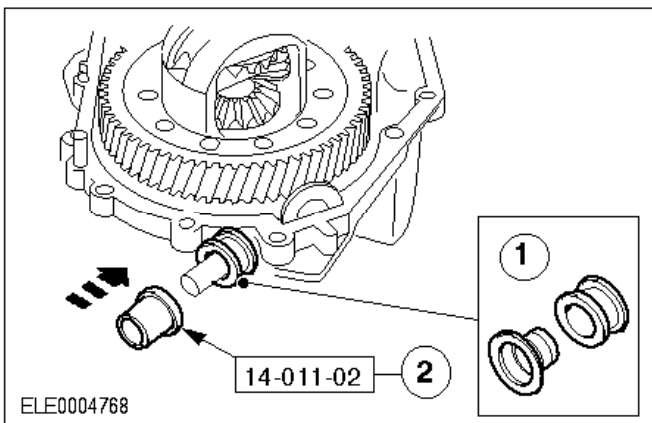

Fit the selector shaft oil seal.



**Note:**

The selector shaft must be clean and free of burrs.

- ⦿ 101. Fit the selector shaft oil seal.

Push the selector shaft inwards.

- 1 Push the oil seal and the assembly sleeve on to the selector shaft.
- 2 Drive in the oil seal just up to the stop.

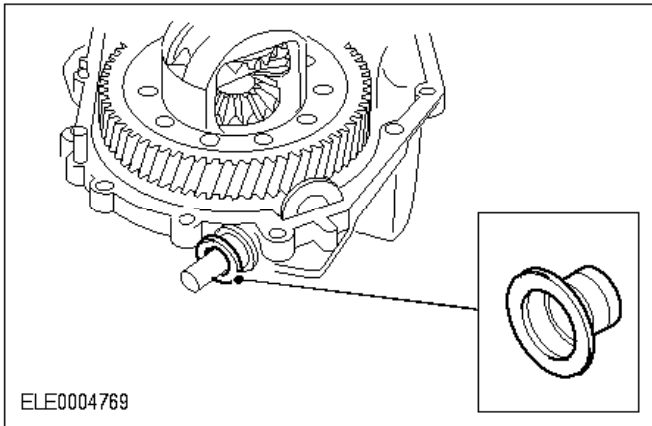

- ⦿ 102. Remove the assembly sleeve, fit the dust cover.

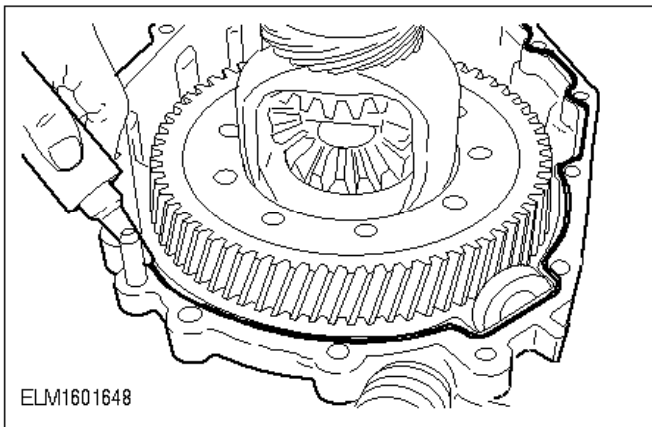

**Note:**

The mating face must be dry. Apply an even bead of sealer (WSK-M2G348-A5) to the inside of the mating face. (The bead of sealer should have a uniform diameter of 2 mm.)

- ⦿ 103. Apply sealer to the mating face.

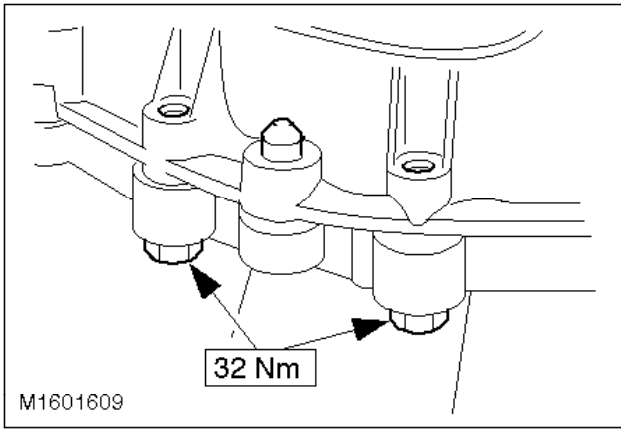

- ⌚ 104. Tighten the transmission housing half on the clutch side.

Note:

The transmission housing must not, under any circumstances, be turned when tightening the bolts.

- Tighten the 16 flange bolts within 15 minutes, working diagonally.

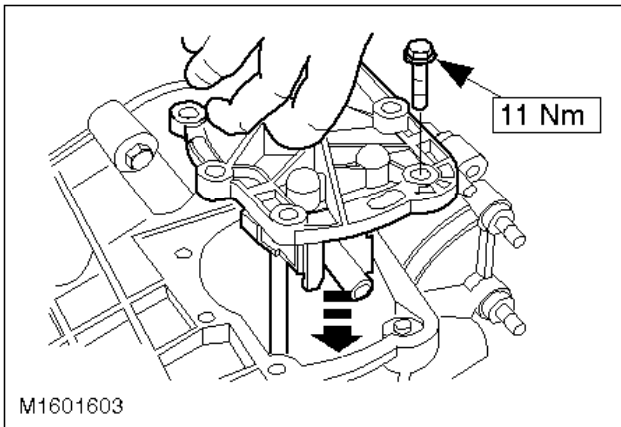

Note:

Put the gearshift mechanism in neutral.

- ⌚ 105. Fit the gearshift mechanism.

- Apply an even bead of sealer (WSK-M2G348-A5) to the outside of the mating face.
- Fit the gearshift mechanism and tighten.

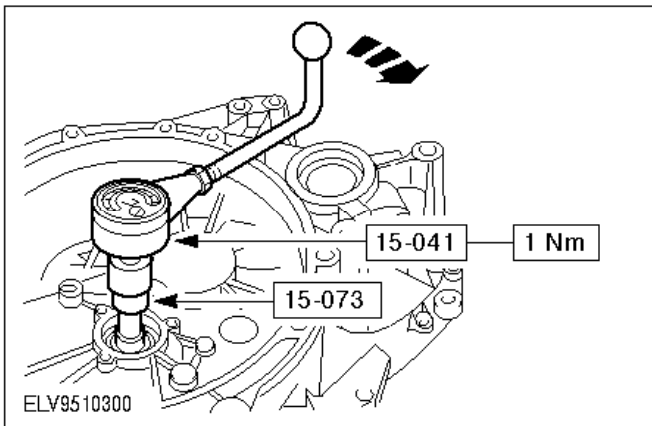

Note:

If the turning torque is too high, all the measurements must be repeated (including the measurement to determine the required shim thickness).

- ④ 106. Measure the turning torque.
  - Engage 4th gear.
  - Measure the turning torque.

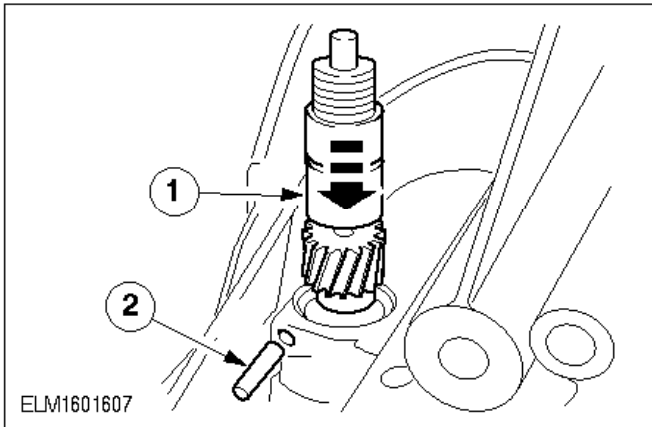

- ④ 107. Install the speedometer drive gear.
  - 1 Install the drive pinion.
  - 2 Drive in the roll pin.

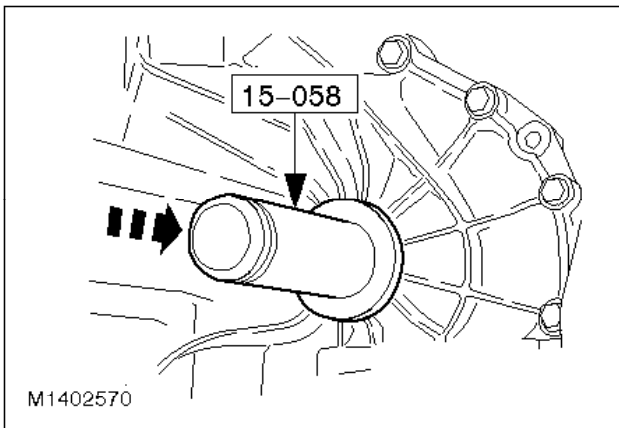

### Fit the input shaft oil seals.

- ④ 108. Fit the oil seals.

Carefully drive in the oil seal up to the stop using the installer.

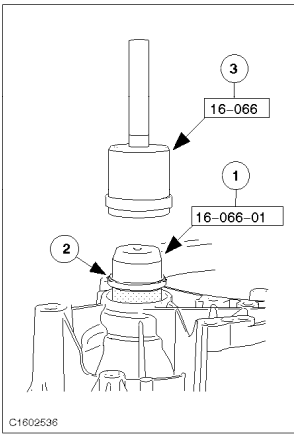

🔩 109. Fit the double lip oil seal.

- 1 Fit the guide sleeve.
- 2 Push on the oil seal.
- 3 Carefully drive in the oil seal up to the stop.

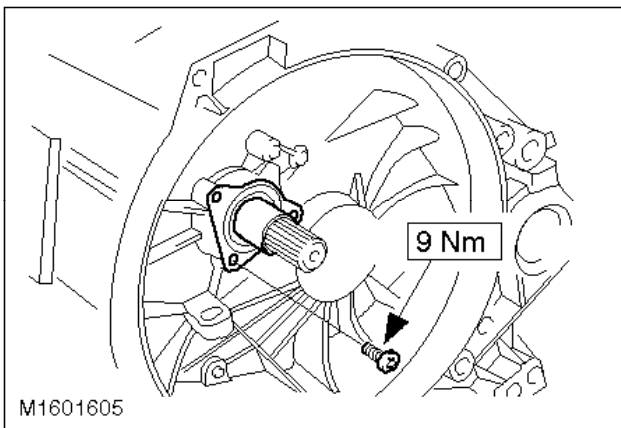

🔩 110. Install the guide sleeve.

Fit the guide sleeve using a new O-ring.

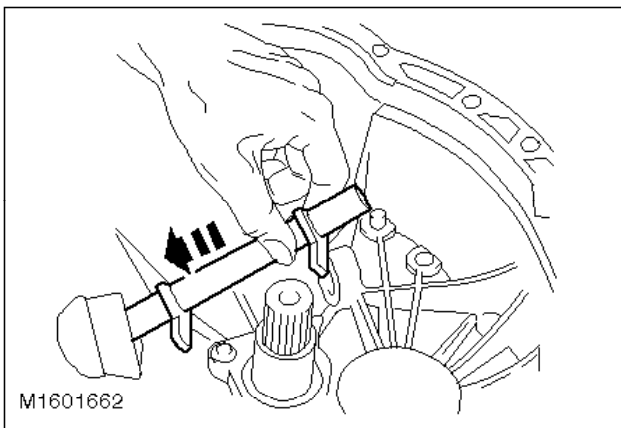

🔩 111. Install the release shaft.

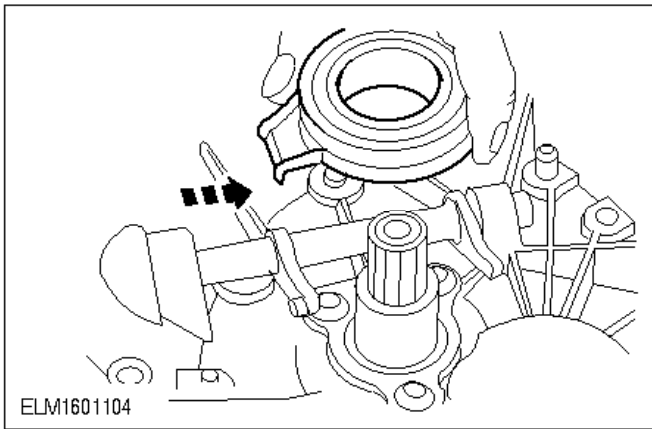

**Note:**

Apply a thin layer of high-temperature grease (ESD-M1C220-A) to the guide sleeve and the clutch splines.

- 112. Fit the thrust bearing.

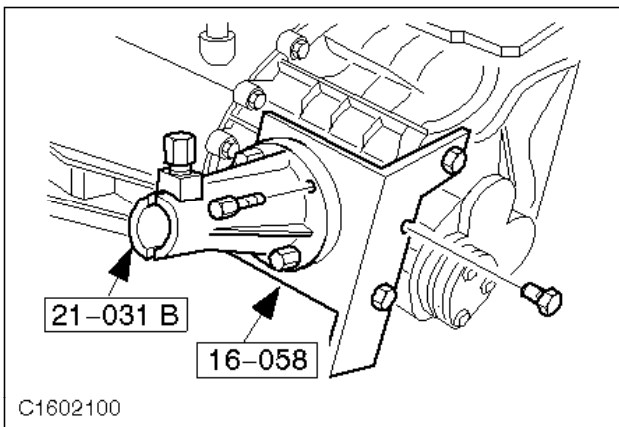

- 113. Remove the special tools.

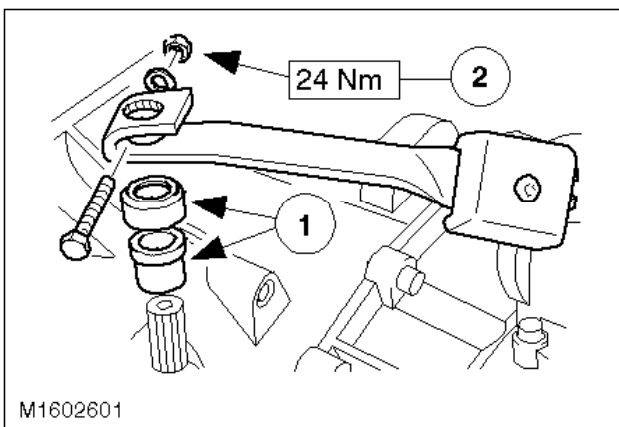

- 114. Install the clutch release lever.

- 1 Fit the bearing bush and the protective cap.
- 2 Fit the clutch release lever and tighten the bolts.